

Certification body

11 rue Francis de Pressensé
F-93571 La Plaine Saint Denis Cedex
Telephone: +33 (0)1 41 62 80 00
Fax: +33 (0)1 49 17 90 00
www.marque-nf.com
www.afnor.org

Body mandated by

AFNOR Certification
39/41 rue Louis Blanc
F-92400 Courbevoie
Telephone: +33 (0)1 47 17 64 85
Fax: +33 (0)1 47 17 62 45
www.certita.fr
certita@certita.fr

CERTIFICATION REFERENCE FOR THE MARK



HEAT PUMP

AFNOR Certification identification no.: NF- 414

Date of the first issue: 01/06/2007

Revision number: 4 – January 2012

Update on: 31 January 2012

CONTENTS

PART 1	APPLICABILITY	6
1.1	Applicability.....	6
1.2	Definitions.....	6
1.3	NF Marking.....	7
1.4	Certified products	8
PART 2	QUALITY REQUIREMENTS TO BE COMPLIED WITH.....	9
2.1	General rules for the NF Mark.....	9
2.2	Standards and additional specifications.....	9
2.3	Requirements for quality control.....	10
2.4	Marking.....	15
PART 3	HOW TO OBTAIN CERTIFICATION.....	20
3.1	Case of an initial application.....	22
3.2	Case of a subsequent application	24
3.3	Case of an application for extension	25
3.4	Case of an application for maintenance.....	26
PART 4	CERTIFICATION MONITORING	27
4.1	Process.....	28
4.2	METHODS FOR FOLLOW-UP inspections	28
4.3	Evaluation and decision	30
4.4	MODIFICATIONS STATEMENT	30
PART 5	PARTICIPANTS.....	32
5.1	Mandated Body	32
5.2	Inspection body	32
5.3	Test body.....	33
5.4	Subcontracting.....	34
5.5	Special Committee	34
PART 6	USE OF MANUFACTURERS' LABORATORIES.....	35
6.1	CASE OF ACCREDITED MANUFACTURERS' LABORATORIES	35
PART 7	RATES	39
7.1	SERVICES RELATING TO NF CERTIFICATION.....	39
7.2	Collecting payment for services	40
7.3	RATES	40
PART 8	CERTIFICATION FILES	41
8.1	CASE OF AN INITIAL CERTIFICATION APPLICATION.....	41
8.2	Case of a subsequent application	41
8.3	Case of an application for extension	41
8.4	Case of an application for maintenance.....	41
PART 9	ADDITIONAL SPECIFICATIONS.....	71
PART 10	SPECIFIC TEST METHODS	72

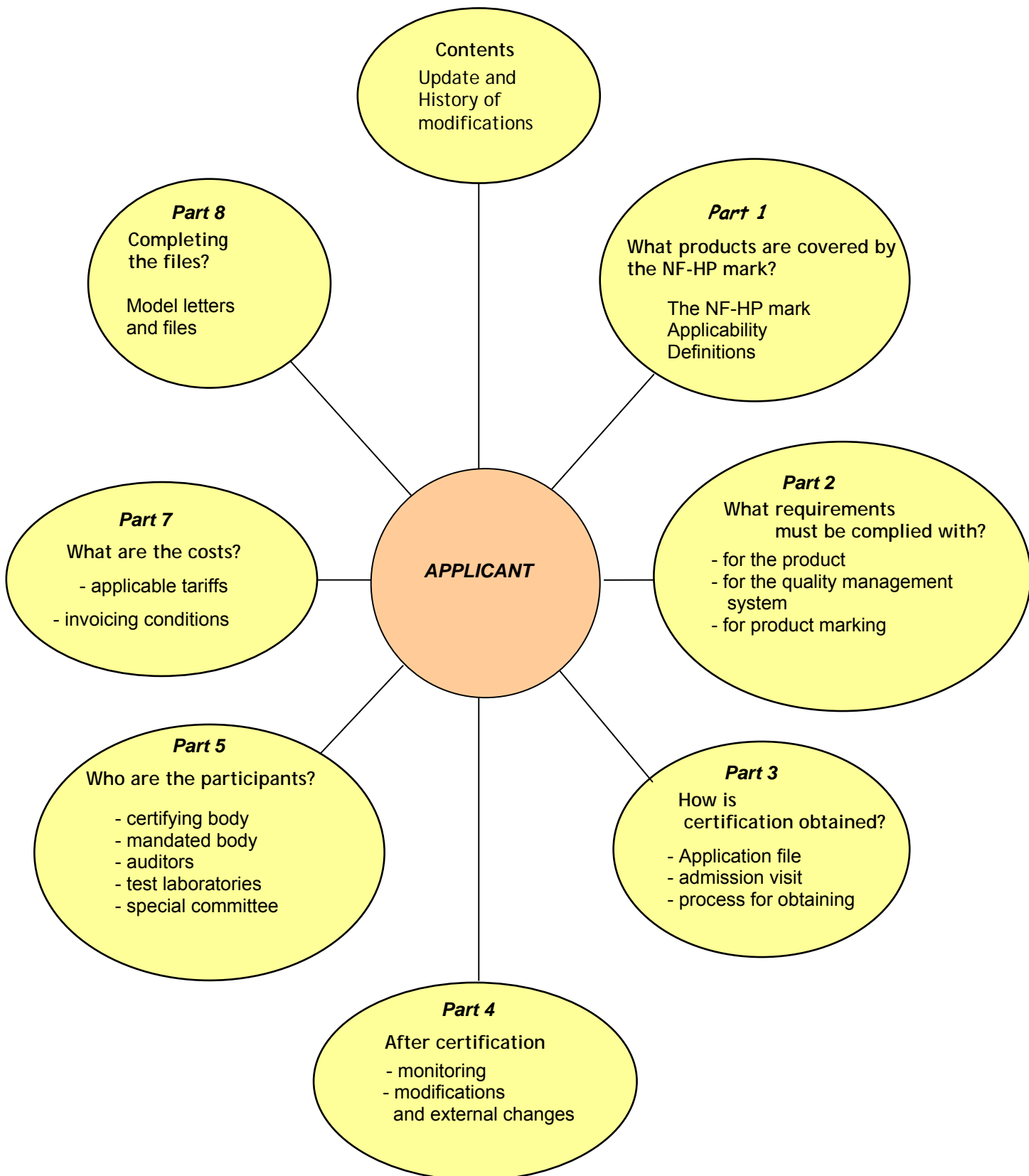

This certification standard was approved by the General Manager of AFNOR Certification on January 31st, 2012.

It cancels and replaces any previous versions.

Along with the holders', users' and technical experts' representatives, CERTITA undertakes to ensure the relevance of this standard, in terms of the certification process and of the definitions of requirements as regards market trends.

The certification rules may be revised, partially or in full, by CERTITA and in all cases after consultation with the Special Committee.

The revision is approved by the General Manager of AFNOR Certification.

HISTORY OF MODIFICATIONS

Part modified	Revision no.	Date of application	Modification carried out
-	0	01/06/2007	Creation of application of NF mark
Whole document	1	20/03/2009	Global reference standard revision
Whole document	2	15/06/2010	Adaptation of the Standard: <ul style="list-style-type: none"> - to swimming pool heat pumps, - certification up to 100 kW, - manufacturing unit monitoring procedure, - test bodies, - sound level threshold.
2	3	01/04/2011	Add of a new temperature condition 22_25°C
Whole document	4	To be completed	Integration of provisions of 2012 thermal regulations (RT 2012). Extension to reversible heat pumps (with chilling function). Change of NF logo Document revision to permit better readability with: Creation of appendices per product category (part 9): <ul style="list-style-type: none"> • Appendix A: Electric HPs • Appendix B: "Swimming pool" HPs and appendices for special test methods (part 10) <ul style="list-style-type: none"> • Appendix AA: Acoustic tests (restatement of 10.2) • Appendix BB: Ground – ground HP tests (restatement of 10.3.3) • Appendix CC: Water – ground HP tests (restatement of 10.4.2) • Appendix DD: External air – ground HP tests (restatement of 10.4.3)

Part 1 APPLICABILITY

The NF mark, owned by AFNOR, has existed for 60 years and is a voluntary mark of conformity to French, European and international standards.

The current reputation of the NF mark is the result of a constant policy of searching for excellence and a desire to meet the changing expectations of the markets: the national market, the European market and the world market.

AFNOR Certification and CERTITA, certification bodies are impartial organisations that provide you with their technical competence in certification, meaning the evaluation and inspection of products and quality control organisation for NF mark holders.

1.1 APPLICABILITY

The products covered by the certification are heat pumps (HP) belonging to the following categories:

- Electrically driven heat pumps for space heating, including machines with a cooling function,
- Electrically driven heat pumps used for heating swimming pool water for seasonal and/or annual use, installed outdoors or inside a building,
- Electrically driven heat pumps covering both the above uses,

The standard applies to heat pumps with a heating capacity less than or equal to 100 kW. However, for the case where the same product is able to work with either glycol water/water, the 100 kW capacity limit is applicable to the lowest power.

In the case of heat pumps with separate components, the assembly of these forms an inseparable system to determine the certified characteristics.

The detail of the products covered and the certified characteristics by heat pump category are given in the appendices of part 9

1.2 DEFINITIONS

Applicant / Holder:

Artificial Person who manages and is responsible for compliance with all of the requirements defined in the certification rules of the NF Mark 414.

Any legal body, designated below, may request a right to use the NF Mark.

- The intellectual property owner of heat pumps,
- the assembler of heat pumps,
- the distributor of heat pumps.

The contractual links that can exist between the applicant/holder and the different supplier to which he subcontracts one of the requirements that cover the following steps: design, manufacture (with the exception of heat pump components), assembly, inspection, marking and packing, must be the subject of a contract as specified in part 8. This defines the commitment by the subcontractors to comply with the certification rules requirements that concern them.

Authorised agent:

Artificial or Natural Person established in the E.E.A who acts as representative of the applicant/holder outside the E.E.A and has a written contractual mandate from the latter meaning that he can act in his name and specifying within what context (associated missions and responsibilities and financial aspects, complaints, certifying body's contact, amongst others) in the NF mark certification process according to the provisions of the certification rules.

The authorised agent may be the distributor, or the importer; their different functions are clearly identified (cf Part 8 of the document).

Distributor:

Artificial Person distributing the applicant's/holder's products who does not act upon the product to modify its conformity to the NF mark requirements.

The types of distributor may be as follows:

- distributors who **have no technical intervention** on the product and distribute the product under the **trademark of the holder**; this scenario does not give rise to any particular demand.
- distributors who have no technical intervention on the product and distribute the product with a **change in trademark**. In this scenario, an application to maintain the right of use must be drawn up, as stipulated in Part 8.
- distributors who have no technical intervention on the product but request modifications that have no impact on the conformity of the product to the NF mark requirements (change in fairing, additional functions (home automation, etc.), colour, etc.) and distribute it with a **change in trademark**. In this scenario, an application to maintain the right of use must be drawn up, as stipulated in Part 8.

1.3

NF MARKING

The NF mark is indicated by the NF logo in accordance with the model below:



HEAT PUMP

or



HEAT PUMP

The graphics charter for the NF mark is available on request from AFNOR Certification.

The provisions concerning use of the NF mark are described in Part 2 of these certification rules.

1.4 CERTIFIED PRODUCTS

The list of certified products is available on the site www.certita.fr

Who to contact to request the right to use the NF mark



39/41 rue Louis Blanc 92400 Courbevoie - France

Tel.: + 33.1 47.17.64.85

Fax: + 33.1.47.17.62.45

Email: certita@certita.fr

Website: www.certita.fr

Part 2

QUALITY REQUIREMENTS TO BE COMPLIED WITH

The reference standard of the "Heat Pump" NF mark comprises the general rules of the NF mark, these certification rules and the standards referred to herein, as well as any additional features.

These certification rules come under the regulatory framework for certification of services and products other than agricultural, forest, food or sea, provided for in articles L-115-27 to L 115-33 and R 115-1 to R 115-3 of the consumer code, taking account of the opinion of the "Conseil national de la consommation" (*National Consumer Council*) dated 17 December 2007.

2.1 GENERAL RULES FOR THE NF MARK

The NF mark is a registered certification collective mark with general rules laying down the general organisation and conditions of use of the mark.

The right to use the NF mark is granted on the basis of compliance with one (or more) standard(s) and more generally to the whole reference standard defined in this part, for a product coming from an applicant and a designated design and/or manufacturing and/or marketing process.

2.2 STANDARDS AND ADDITIONAL SPECIFICATIONS

2.2.1 Regulations

The products covered by these certification rules must comply with the French regulations in force. They are manufactured so as to meet all of the directives and regulations in force that are applicable to them.

2.2.2 Standards

The standards for each product type or specific tests methods are given in part 9 or part 10.

Standard concerning the quality management system

NF EN ISO 9001:2008, *Quality management systems – Requirements*.

NF EN ISO/CEI 17025:2005 *General requirements for the competence of testing and calibration laboratories*

2.2.3 Additional specifications

The additional specifications for each type of product covered by the applicability of the present reference standard are given in:

- Appendix A part 9, for electrically driven heat pumps for space heating, including machines with a cooling function,
- Appendix B part 9, for electrically driven heat pumps used for heating swimming pool water for seasonal and/or annual use, installed outdoors or inside a building,

2.3 REQUIREMENTS FOR QUALITY CONTROL

2.3.1 Purpose

The applicant/holder and their distributors are each responsible, as far as they are concerned, for the right to use the NF mark for the product being considered.

The applicant/holder shall take every step necessary to guarantee the compliance of the product with these certification rules on an ongoing basis.

This paragraph defines the minimum provisions that the manufacturer shall set up in terms of quality management so that the products covered by the NF mark are produced at all times in compliance with these rules.

This paragraph constitutes the audit reference standard.

The quality system is partly based on the manufacturer setting up a series of organisational provisions to control the compliance of the products delivered with standards and additional specifications, where applicable. These provisions are described in paragraphs 2.3.2 and 2.3.3.

These provisions can be completed by specific requirements related to the type of product certified. In this case they are given in part 9 of the present reference standard.

2.3.2 Minimum requirements for quality management

The holder must have implemented his own means, the presence and effectiveness of which are assessed using the applicable requirements of standard NF EN ISO 9001 (in force), in accordance with the following table.

§	TITLE	Quality organisation requirements
4	Quality management system	
4.1 4.1 a) to e).	General requirements	Identify the processes associated with product manufacture, their interactions; provide resources, control and monitoring for it.
4.2	Documentation requirements	
4.2 .1	General	The documentation must include a quality policy, a manual, some procedures, the description of processes and the records.
4.2 .2	Quality Manual	<u>Comment:</u> The scope of the documentation can differ depending on the size of company, the complexity of the processes described and the competence of people.
4.2.3	Document control	The NF mark application files must be managed and controlled. Should the product be modified, the managing body must receive information thereof. The standards and these certification rules must be managed.
4.2.4	Records	Records (in paper and/or digital format) must be kept for: <ul style="list-style-type: none"> - A minimum of 10 years: for product files; to comply with the requirements of European (CE marking) and regulatory directives. - A minimum of 5 years: for all records of product inspections. From receipt to storage, as well as customer complaints.
5	Management responsibility	
5.1	Management commitment	To communicate the importance of satisfying the customer requirements, prepare a quality policy, establish quality objectives, management reviews, resources. <u>Comment:</u> A commitment must also be made concerning the NF mark certification rules.
5.3	Quality policy	Applicable in full
5.4.1	Planning objectives	Applicable in full
5.5	Responsibility, authority and communication	
5.5.1	Responsibility and authority	Applicable in full
5.5.2	Management Representative	Applicable in full
5.5.3	Internal communication	Applicable in full
5.6	Management review	
5.6.1	General	Management must, at planned intervals, review all of the

		requirements linked to the NF mark.
6	Resource management	
6.1	Provision of resources	Applicable in full
6.2	Human resources	
6.2.1	General	Applicable in full
6.2.2	Competence, awareness and training	Applicable in full
6.3	Infrastructure	Provide and maintain the buildings, equipment and supporting services needed to ensure product conformity.
7	Product manufacture	
7.1	Planning of product manufacture	The requirements of these Rules must be taken into account.
7.2.3	Communication with customers	Applicable in full
7.4	Purchasing	The body must set up and implement inspections or other activities required to ensure that the purchased product meets the specified purchasing requirements.
7.5	Production and preparation of service	
7.5.1	Control of service preparation and production	<u>Comment:</u> Service = product
7.5.2	Validation of production processes and service preparation	The processes associated with product manufacture
7.5.3	Identification and traceability	Applicable in full
7.5.5	Product preservation	Applicable in full
7.6	Control of monitoring and measuring equipment	Applicable in full
8.2	Monitoring and measurement	
8.2.2	Internal audit	Checks should at least be made that the requirements of these rules are complied with.
8.2.4	Product monitoring and measurement	Applicable in full
8.3	Control of nonconforming product	Applicable in full For nonconforming products, the NF mark must be withdrawn.
8.4	Data analysis	Restricted to paragraphs b and d.
8.5	Improvement	
8.5.2	Corrective action	Applicable in full <u>Additional requirement for the NF mark:</u> Records of complaints regarding certified products and their processing must be made and kept.
8.5.3	Preventive action	Applicable in full

The audits may be reduced for companies with a certified quality management system complying with standard NF EN ISO 9001 (in force), provided that:

- the ISO certificate includes, within its perimeter and its scope, the sites and activities covered by the NF mark;

- the ISO certificate was issued by an authorised certifying body:
 - the ISO certificate was issued by a certifying body accredited by COFRAC or by an EA member (European cooperation for Accreditation) – see members on the COFRAC website (www.cofrac.fr) – and recognised by AFNOR Certification: the reduction can be implemented when the certificate is sent to CERTITA,
 - the ISO certificate is issued by AFNOR Certification under coordinated certification provision: the reduction is implemented according to the rules described in the procedures in force for implementing coordinated certifications.

During the audit, the auditor/inspector is entitled to consult the quality management system audit reports of the ISO certifying body.

In all cases, the reduction may be evaluated again if the conditions having authorised it are no longer met.

2.3.3 Requirements specific to products

General

The manufacturer must have the necessary resources and means during the inspections and tests to guarantee product conformity.

The manufacturer must set up a documented inspection plan that must, as a minimum, include the inspections and tests described in the following paragraphs and the complementary requirements defined in part 9.

The inspection results must be recorded in registers or other documents kept for this purpose and retained in accordance with a documented procedure.

The inspections individually defined in the paragraphs below and in part 9 will also have to be documented.

The inspection results must lie within the tolerances defined in the inspection instructions.

2.3.3.1 Control of suppliers and subcontractors

The manufacturer must carry out an incoming goods inspection by sampling or any other evaluation over all the constituent elements involved in the assembly of the heat pumps, in order to ensure their compliance.

2.3.3.2 Inspections during manufacturing

2.3.3.2.1 Qualification of brazers/welders

All operators working on all permanent assemblies (such as brazing, welding, gluing, expansion, enlarging, etc.) must be qualified and the manufacture must be able to prove this.

The manufacturer must be able to trace the product back to the operators who carried out the permanent assembly operations.

2.3.3.2.2 Leak test (100% inspection)

The manufacturer is obliged to carry out leak tests on his products by any appropriate means. The effectiveness of the device must be proven.

In the event of a defect being observed, the proper operation of all the circuits previously made since the last check must be carefully checked for resumption of tightness.

- On the hydraulic circuit
- On the refrigeration circuit

The manufacturer must carry out a leak test of the refrigeration circuit at the operating pressure of the heat pump. Several techniques can be used for this test depending on the production conditions. For example, pressurisation with an inert gas (or other similar methods).

The test method used to detect the leaks must have the same sensitivity as the bubble test (described in standard EN 1779). Standard ISO 5149-2 can also be used. The relevance of the method used must be proven by the manufacturer.

2.3.3.2.3 Load in liquid refrigerant on the factory "packaged unit" (100% inspection)

The methods used to get the vacuum in the refrigeration circuit, before loading the liquid refrigerant, must allow the residual pressure of air to drop and be monitored at less than 10 kPa (10^{-1} bar).

The conditions in which the liquid refrigerant is stored and the amount of liquid refrigerant injected in the refrigeration circuit must be controlled and managed.

In the event of a defect being observed, the proper operation of all the refrigerated circuits previously made since the last check must be carefully checked for reload.

2.3.3.2.4 Tightness of a refrigeration circuit for an installation filled on the site where used (100% inspection)

In the event where the filling is done at the time of installation, each constituent element of the system must comply with the criteria of 2.3.3.2.2, to guarantee that the elements delivered to the installer are in accordance with the tightness requirements.

Before filling the installation, its global tightness must be checked by the fitter, according to the manufacturer's instructions indicated in a manual supplied with the appliance.

2.3.3.2.5 Production test for electrical safety, according to NF EN 50106 (100% inspection)

The electrical safety tests must be carried out in accordance with the requirements of standard NF EN 50106 (according to paragraphs 1.1 and 1.2).

2.3.3.3 Inspections on the finished product

2.3.3.3.1 Tests at the end of assembly line (100% inspection)

Each manufactured product must be put into use at the end of the assembly line to check that it works properly.

2.3.3.3.2 Inspection of marking

Periodic inspections shall be carried out to ensure the compliance of and presence of the marking on the certified product, as defined in § 2.4 of this certification standard.

2.3.3.3.3 Appearance inspection before packaging (100% inspection)

Appearance inspections must be carried out before the product is packaged.

All of the inspections and tests carried out throughout the assembly process must be validated and recorded.

2.3.3.3.4 Availability of spare parts

The manufacturer must draw up a procedure defining the measures to take to guarantee the availability of spare parts for 10 years, once a product is no longer marketed.

Should components be modified, the manufacturer shall assess the impact on manufactured products that have already been delivered and offer replacement solutions that guarantee the performance of the HP. Records must be kept up-to-date and stored.

2.3.3.3.5 Documentation control

The holder shall check all documents (technical, installation and sales documents, manuals, web sites, etc.) that mention the certified features and the NF logo (as defined in part 2 below) before they are circulated. This check shall be validated and recorded by competent, identified persons.

The holder shall also ensure that it controls its applications for the right to use the NF mark, in order to inform CERTITA of any modification of elements forming them, particularly if they affect the certified features.

2.4 MARKING

Marking is an integral part of the certification of a product.

Beyond the identification of a certified product and its traceability, the marking of a product with the NF logo ensures better protection of the mark and facilitates legal proceedings and sentencing of forgeries.

Furthermore, giving the main certified features is an advantage for consumers and promotes the certification and its content.

2.4.1 The NF logo

The NF logo must ensure identification of every certified product.

The NF certified product must bear a designation and identification distinct from non-certified products.

The holder must only use the NF logo to distinguish certified products, without risk of any possible confusion with other products, particularly with non-certified products.

The graphic tools for the logo (film, floppy disk, etc.) are available from CERTITA and on the website www.marque-nf.com, "holders" section.

The holder is recommended to submit all of the documents relating to the NF mark to CERTITA beforehand.

2.4.2 Reference texts

The French consumer code: a desire for transparency

Communication of information concerning product and service certification is governed by regulations which seek to make the meaning of labels, certification marks and so on apparent to users.

Accordingly, article R 115-2 of the French Consumer Code stipulates that:

"Where reference is made to certification in advertising, on labelling or the presentation of any product or service, and in commercial documents of any kind relating thereto, the following mandatory information shall be provided to the consumer or user:

- the designation or company name of the certifying body or the collective certification mark,
- the name of the certification standard used,
- the manner in which the certification standard can be consulted or obtained."

General rules of the NF Mark

The purpose of the marking rules given below is to guide the holder in how to meet the regulations and the requirements of the NF mark. Articles 4, 11, 14 and 15 of the general rules of the NF mark specify the conditions of use, of validity and the penalties in the event of abusive use.

The holder shall only use the NF mark in his documents (paper and electronic format) for certified products and only if there is no risk of confusion and interpretation.

2.4.3 Marking process

This paragraph describes both the process for affixing the NF logo and the marking of the certified features. A "certified feature" is any information whose content is controlled under the NF mark scheme.

It covers the three following aspects:

1. Marking of the NF logo on the NF certified product
2. Marking of the NF logo on the packaging of the NF certified product, if applicable
3. Marking of the NF logo on documentation and on websites

2.4.3.1 Marking of certified products

The NF logo shall be permanently and indelibly affixed to the thermodynamic device for which the right to use the NF-HP mark has been obtained.

The marking of the product shall comply with the following logo (French or English version)



HEAT PUMP



HEAT PUMP

The heat pump categories (for example: heating – swimming pools) can be indicated under the above logo on a maximum of 2 lines and according to the NF mark graphical charter.

For splits, the NF logo shall be affixed to the outdoor and indoor units. However, if not all of the units offered in the holder's catalogue are covered by the combinations defined in the ranges for which the NF mark has been obtained; no NF logo shall be affixed. In this case the holder must make the following wording appear on the indoor and outdoor unit rating plates "Combinations admitted for the NF mark: See installation and user manuals".

2.4.3.2 *Reproduction of the NF logo on the packaging of the certified product*

When the packaging mentions the NF mark, it shall include the NF logo in accordance with the corporate identity.

2.4.3.3 *Reproduction of the NF logo on documentation and in advertising*

(Technical and commercial documents, labels, posters, advertising, websites, etc.)

The NF logo must be reproduced on the documentation in accordance with the corporate identity and if applicable with the conditions for which the products benefit from the right to use the mark, as defined in paragraph 2.4.3.1.

The holder shall only use the NF mark in the document to distinguish certified products and when there is no risk of confusion and interpretation. For this reason, the publications shall include a chapter explaining the coverage of the certificate.

Reproduction of the NF mark on the holder's letterhead is not allowed, unless the holder has the NF mark for all of his production.

For a correct interpretation of this paragraph, the holder is recommended to send all documents relating to the NF mark to CERTITA.

Marking example

In accordance with decree R115-2 of the Consumer Code (see 2.4.2), all documentation concerning the NF certified product must have the following form:



NF-414 (to meet the identification requirements of this standard)

Consultation of the Standard: www.marque-nf.com – www.certita.fr (to meet the requirements of the procedure for consulting this standard)

Examples of additional information that can be given with the marking:

- . Name and address of manufacturer,
- . Product designation,
- . Identification of the certification reference standard,
- . Certified features,
- . Certificate number,
- . Details of the construction, including the dimensions and weight,
- . Identification of the main components,
- . Detailed user's instructions, including the explanation of any marking using a symbol,
- . The details of all operating maintenance required as well as its frequency,
- . Information about how to deal with a fault,
- . Product operating condition,
- . Reference to environmental noise regulations.

2.4.4 Information on the certified features

Without prejudice to the sanctions laid down in article 11 of the general rules of the NF mark, any incorrect announcement of the certified features exposes the holder to lawsuits for frauds and/or misleading advertising.

2.4.5 PROVISION ON DOCUMENTATION

The purpose of this paragraph is to set out the additional requirements of the NF mark, to be shown in the holder's documentation (*technical, installation and sales documents, manuals, web sites, etc.*).

- For refrigerated circuits loaded on the site of use, the holder must indicate the instructions on assembly, loading and overall verification of the tightness of the appliance in the installation manual. The holder may refer to standard ISO 5149-2 to define the installer's obligations.

- For heat pumps using groundwater and for which the certified features have been determined without barrier exchanger, the holder must clearly mention near the announcement tables the text: "Tests to assess the performance of the heat pumps have been carried out without barrier exchanger. If this component is used on the installation, the performances are reduced and the stated features no longer certified".
- For heat pumps that cannot be marked with the NF logo, as defined in paragraph 2.4.3.1, the holder shall produce a specific chapter entitled "combinations permitted for the NF mark" that reproduces the certificates of right of use of the NF mark
- For splits, if all the units offered in the holder's catalogue are not covered by combinations defined in the ranges allowed to use the NF mark, the installation and user manuals must contain a chapter "combinations allowed to use the NF mark", which must include a copy of the certificate of right to use the NF mark.
- For multi-application heat pumps, of which not all of the applications would be admitted for the NF mark, the installation and user manual must state the applications for which the product benefits from the NF mark.

2.4.6 DRAFT DOCUMENTATION

So that the holder ensures that the requirements of the NF mark are correctly interpreted and to avoid any return of his document(s), he is recommended to send it (them) to CERTITA for opinion.

Part 3

HOW TO OBTAIN CERTIFICATION

Definition of the applicant (see 1.1),

An application for the right to use the NF mark can be:

- A first request of admission: this is submitted by an applicant who does not have the right to use the NF Mark in the application concerned. This corresponds to a product (or a range of products) from a particular production unit, defined by a trademark, a commercial reference specific to the product introduced and its technical features;
- a request for later admission of a new product or a new manufacturing unit: this is submitted by an applicant who has the right to use the NF Mark in the application concerned;
- An extension application for a product whose certified features have been modified (or in a modified range), or an addition of model(s);
- An application to maintain use for an NF certified product that will be marketed with a different brand and/or commercial reference without any change in its certified features.

Process

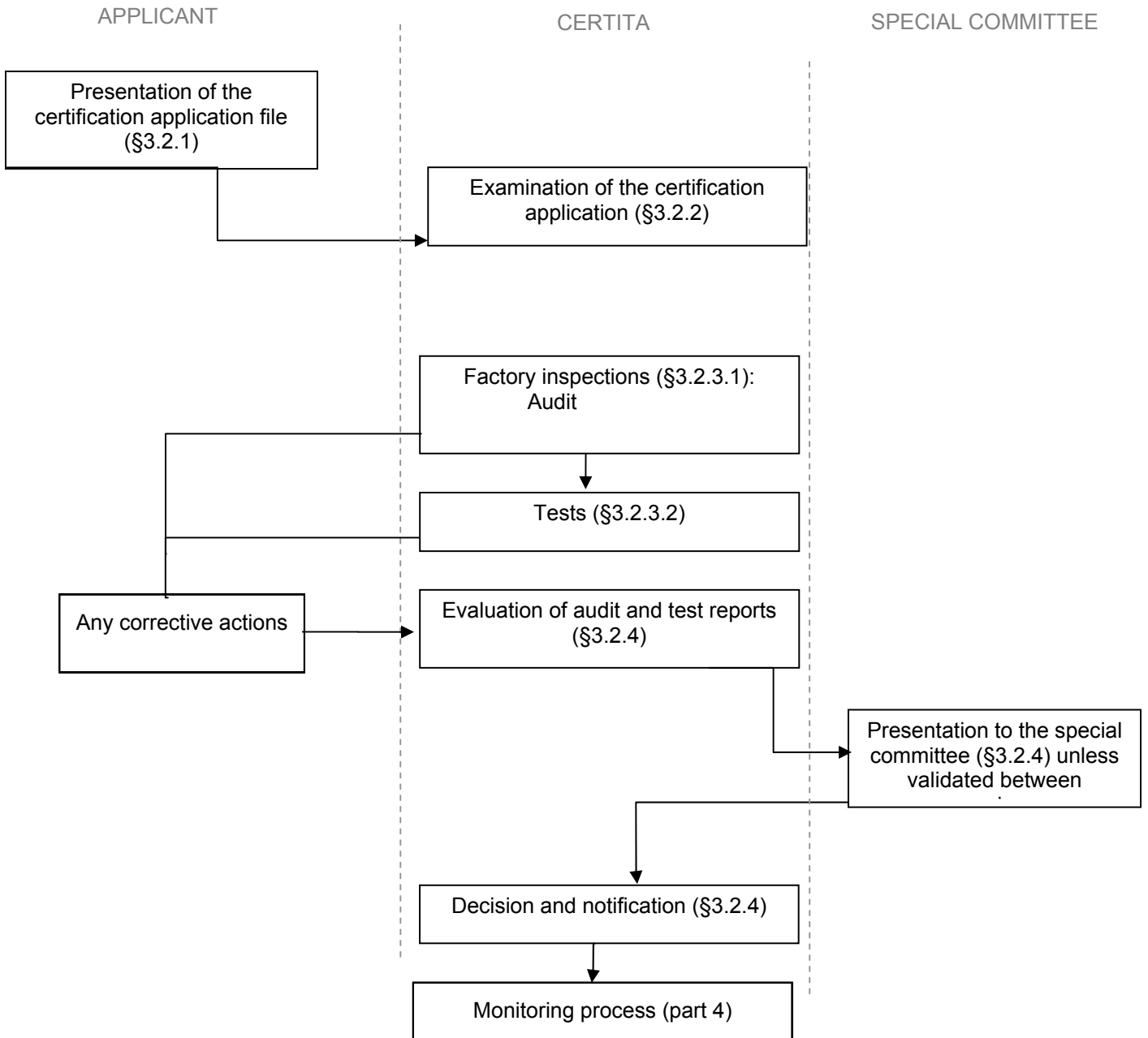

3.1 CASE OF AN INITIAL APPLICATION

3.1.1 Presentation of the certification application file

Before making the application, the applicant must be sure to meet, at the time of the application, the conditions defined in these Certification Rules, especially those in Part 2, regarding his corresponding product and sites. He must undertake to comply with said conditions throughout the period of using the NF mark.

The application shall be presented in accordance with the conditions and templates included in Part 8.

3.1.2 Admissibility study of the certification application

Upon receiving the application, CERTITA checks that:

- all the necessary documents are attached to the application;
- the products included in the application fulfil the technical specifications established in Part 2 of these Rules.

CERTITA may request additional information required for the admissibility of the file when this is incomplete.

Once the application is admissible, CERTITA organises the inspections, and informs the applicant about the organisation methods (auditor, duration of the audit, audited sites, laboratories, sampled products, etc.).

3.1.3 Inspection methods

The inspections carried out for the NF mark are generally of two different types:

- audits conducted during visits to the manufacturing units;
- tests on the submitted products.

3.1.3.1 Audits

The audit will last least **one day**.

The visit, carried out by an NF inspector/auditor, has the purpose of ensuring that the measures defined and implemented by the applicant during the audited design and/or manufacturing and or marketing process meet the corresponding requirements established in Part 2 of these certification rules. The report(s) shall, when required, include a response request within a time frame set in the report mailing.

For situations in which the company subcontracts a part of their activity, CERTITA reserves the right to send an NF inspector/auditor to visit the subcontractor(s) in the same terms established in these rules.

The NF inspector/auditor must be provided with all the resources necessary (offices, installations, facilities) to perform his assignment, including competent people to carry it out.

Samples may be identified and/or taken during the visit for examinations or tests.

An audit report is prepared and sent to the applicant. This report, depending on each case, can be sent to the applicant before or after the evaluation. It can be sent by the auditor, the inspection body or CERTITA.

3.1.3.2 Tests

The tests are performed under the NF Mark laboratories' responsibility.

The tests are carried out in accordance with the standards and additional specifications established in Part 2.

A test report is drawn up and sent to the applicant and to CERTITA.

Depending on the nature of the equipment and test and study means of the applicant, CERTITA may, for some categories of appliances that he has or will have defined, authorise the applicant to conduct the required tests in his own laboratories according to a specified procedure described in Part 6.

For tests which the applicant is not allowed to perform on his own, the tests will be performed in one of the laboratories mentioned in article 5.3 of Part 5 of these certification rules.

Each product will be tested depending on its admission as indicated in the table below:

Number of products in range	Number of products tested
1	1
2	1
3	1
4	1
5	1
6	2
7	2
8	2
9	2
10	2
> 10	3 (up to 15 then 1 additional reference per step of 5)

For acoustic power characteristics, 1 product will be subject to test whatever the number of products in the range.

- For multi-split heat pumps:

The number of tested product(s) is determined by taking account of the table above. It is used to define the number of outdoor units (OUs) and number of indoor units (IUs) for each type (apron wall, wall, ceiling, etc.). Multiplication of the number of OUs by the number of IUs selected produces the maximum number of combinations to test.

In view of the test method and test means of the laboratory, i.e.:

- IU connection of the same model in the same range,
- provision of two or even three climatic chambers to test a combination with two types of IU, if necessary.

Together with the laboratory, CERTITA shall study the combinations that may be tested carefully, to minimise the number of tests validating all of the OU and IU models selected.

Moreover, depending on the combinations selected, it will at least:

- test a combination that reaches 80% of the nominal capacity of the associated OU during operation (at 7/6_20/15 °C) and,
- test a combination that reaches 120% of the nominal capacity of the associated OU during operation (at 7/6_20/15 °C).

None of the other combinations will have to meet a specific criterion within the 80%-120% range of capacity of the OU.

3.1.4 Evaluation and decision

CERTITA assesses the report(s) intended for the applicant in accordance with the current procedures (transmission after evaluation or handing out of the report on site).

The applicant must present, for each deviation, the actions taken or to be taken, including the schedule to put them in place.

CERTITA analyses the relevance of the response and is entitled to request an additional inspection (full or partial audit and/or tests).

Possible consultation of the Special Committee: if necessary, CERTITA may present all of the evaluation results anonymously to the Special Committee for opinion.

Depending on the results of all inspections, CERTITA notifies one of the following decisions:

- granting of the right to use the NF mark
- rejection of the right to use the NF mark

CERTITA then sends an NF Certificate to the holder and/or a document notifying the decision,

The methods for communicating about the certification are defined in Part 2.4 of these certification rules.

The applicant may object to the decision made by submitting a claim in accordance with Article 12 of the General Rules of the NF Mark.

3.2 CASE OF A SUBSEQUENT APPLICATION

The application shall be presented in accordance with the conditions and templates included in Part 8.

The stages described in paragraph 3.1 are applicable with the following specific feature: the audit can be adapted or joint with a surveillance audit.

3.3 CASE OF AN APPLICATION FOR EXTENSION

The application shall be presented in accordance with the conditions and templates included in Part 8.

The stages described in paragraph 3.1 will be applicable subject to the following specificities:

- in the case of a request for extension for a certified range of products that is modified, the tests defined will depend on the envisaged modification.

The number of products to be tested is defined as follows:

Number of products in the range	Number of products tested
1	1
2	1
3	1
4	1
5	1
≥ 6	2

- for extension applications for the addition of products to a certified range, having the same components as defined in § 3.1.1, the number of products to be tested is determined by adding the added products to those already certified.

The number of products to be tested is defined as follows:

Number of products in range (after addition of models)	Number of products tested
2	0
3	0
4	0
5	0
6	1
7	1
8	1
9	1
10	1
> 10	2 (up to 15 then 1 additional reference per step of 5)

- for an application for extension corresponding to the addition of an application (new matrix line) for an already certified range, the number of tests to be made to certify this new application is set at 1 on a model from the range.
- the audit can be adapted or combined with a monitoring audit.

3.4

CASE OF AN APPLICATION FOR MAINTENANCE

The application shall be presented in accordance with the conditions and templates included in Part 8.

For distribution through different commercial brands, certain modifications in appearance may be made to the products in question if they do not entail any functional change. The manufacturer shall then specify in the maintenance application the list of modifications made to the products in question. CERTITA ensures that said modifications have no impact on function.

Part 4 CERTIFICATION MONITORING

Throughout certification, the holder must:

- comply with the requirements defined and the marking methods described in Part 2;
- update the certification file;
- systematically inform CERTITA of any change in the certified product's features.

CERTITA will follow up the certified products as soon as the right to use the NF Mark is granted. This follow up will include audits and tests on the products.

It will also include monitoring of how the mark and logo are used on products and every communication document.

The NF mark is awarded to a product from a particular manufacturing unit, defined by a trademark, specific commercial reference and technical characteristics. As a result, any modification to the conditions to obtain the NF mark must be reported by the holder in writing to CERTITA.

In addition, CERTITA is entitled to carry out or have carried out any additional audit or test it deems necessary as a result of complaints, disputes or litigations they are aware of in connection with the use of NF mark.

Inspections may be carried out on the market.

In the event of disputes with users, inspections may include sampling or tests on the sites of use (in this case, the holder is invited to send a representative there).

4.1 PROCESS

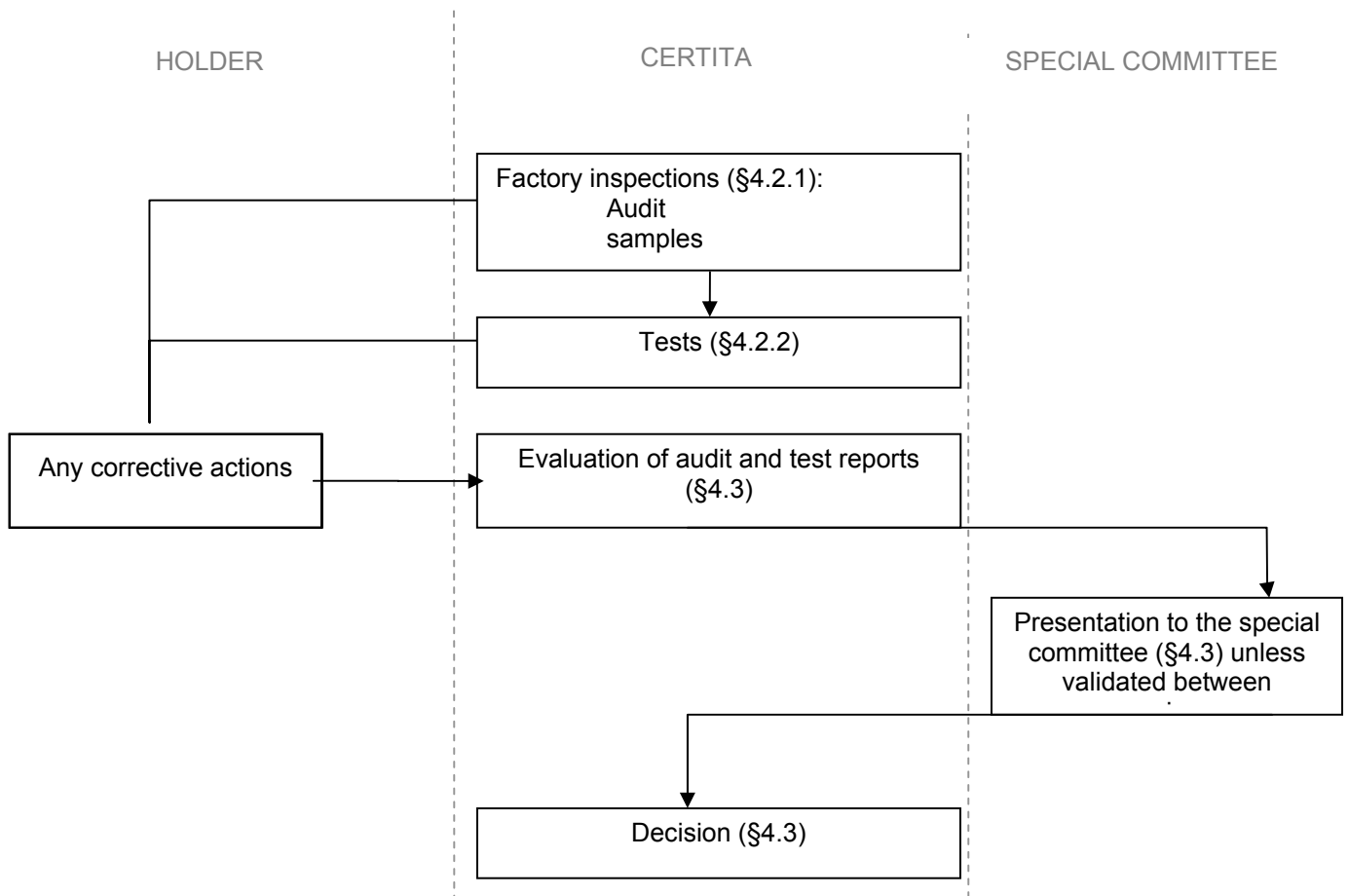

4.2 METHODS FOR FOLLOW-UP INSPECTIONS

The follow up methods depend on the decisions made as a result of previous inspections. They consist of audits of the manufacturing unit and tests on products.

4.2.1 Audits

4.2.1.1 Purpose

The audit will last at least **one day** and be carried out **once a year**.

The visit, carried out by an NF inspector/auditor, has the purpose of ensuring that the measures defined and implemented by the applicant during the audited design and/or manufacturing and or marketing process meet the corresponding requirements established in Part 2 of these certification rules.

For situations in which the company subcontracts a part of their activity, CERTITA reserves the right to send an NF inspector/auditor to visit the subcontractor(s) in the same terms established in these rules.

The NF inspector/auditor must be provided with all the resources necessary (offices, installations, facilities) to perform his assignment, including competent people to carry it out.

Samples may be identified and/or taken during the visit for examinations or tests.

An audit report is drawn up and sent to the holder. This report, depending on each case, can be sent to the holder before or after the evaluation. It can be sent by the auditor, the inspection body or CERTITA.

4.2.1.2 *Frequency of the audit visits*

Normal monitoring of the manufacturing units

The normal frequency is **one audit per year for each manufacturing unit**.

Reduced monitoring of manufacturing units

After the first follow-up audit has been performed, the normal audit frequency of one year may be brought to one audit every 2 years if the holder complies with the following conditions:

- ✓ any deviations found during the previous audit are lifted and the actions put in place are effective,
- ✓ the audit did not highlight any critical deviation from the NF HP requirements, that is, any deviation that calls into question the compliance of the product with the requirements of the NF HP standard,
- ✓ the follow-up test results comply with reference specifications.

Once reduced monitoring has been set up, non-compliance with one of the above 3 conditions leads to a return to normal monitoring and therefore an annual audit.

Increased monitoring schedule

In the event of breach of these certification rules, the reinforced monitoring procedure may be set up for a defined period of time. This may be adjusted as far as doubling the normal frequency of audits, with or without reinforcing the manufacturer's inspections and samples for the tests.

4.2.2 **Tests on the NF certified product**

The tests are performed in accordance with the standards established in Part 2 Para.

Each year, 2 products from different ranges are chosen as samples to perform the laboratory tests described in § 5.3.

The products to be sampled are chosen by CERTITA. It informs the holder of the appliances to be manufactured in advance in order to enable the auditor to identify them during his audit assignment. In the absence of a monitoring audit, CERTITA approaches the holder to tell it which products to manufacture and organise their sampling.

A test report is produced by the laboratory and sent to the holder by CERTITA.

For those holders who have an authorised laboratory (according to these rules), one of the two sample products will be subject to an inter-comparison with a laboratory stated in Para. The other product will be tested in its authorised laboratory. For the latter, a test report is drawn up and sent to CERTITA.

For each HP type, the allowable tolerances relative to the certified values are given in part 9 of the present standard.

When considering a range of products, if the test results for a sample product are different from the certified features, except from the defined tolerances, all the values of the range's certified features must be changed on the basis of the test report results for the tested product.

4.3 EVALUATION AND DECISION

CERTITA assesses the report(s) intended for the holder in accordance with the current procedures (transmission after evaluation or handing out of the report on site).

The report(s) shall, when required, include a response request within a time frame set in the report mailing.

The holder must present, for each deviation, the actions taken or to be taken including the schedule to put them in place.

CERTITA analyses the relevance of the response and is entitled to request an additional inspection (full or partial audit and/or tests).

Possible consultation of the Special Committee: if necessary, CERTITA may present all of the evaluation results anonymously to the Special Committee for opinion.

Depending on the results of all inspections, CERTITA notifies one of the following decisions:

- Renewal of the right to use the NF mark
- Suspension of the right of use during a certain period, together with corrective actions by a specific deadline;
- Withdrawal of the right of use, without prejudice of further legal proceedings in accordance with article 15 in the General Rules of the NF mark.

CERTITA then sends an NF Certificate to the holder and/or a document notifying the decision,

The methods of communication about certification are set out in part 2.4 of this certification standard.

The holder could object to the decision taken by submitting a claim in accordance with Article 12 of the General Rules of the NF mark.

4.4 MODIFICATIONS STATEMENT

This paragraph states what information is needed and the steps to take in the event of modifications concerning:

- the holder;
- the manufacturing unit;
- the quality organisation of the manufacturing unit;
- the product.

For other cases, CERTITA determines whether the modifications could cast doubt over the certification and whether an additional inspection is necessary.

Depending on the examination results, CERTITA's President notifies the appropriate decision.

4.4.1 Modification concerning the holder

The holder shall report in writing to CERTITA any legal modification of the company or any change in the company's name.

In case of merger, bankruptcy or absorption of the holder, all the rights to use the NF Mark from which the holder may benefit cease automatically.

A new application may be submitted, and its examination reduced depending on the modifications.

4.4.2 Modification regarding the manufacturing unit

The holder shall declare the transfer in writing to CERTITA who organises an audit of the new manufacturing site, and if necessary, will also perform tests.

Any transfer (total or partial) of the manufacturing unit of an NF certified product to a different manufacturing unit brings about an immediate cessation of NF marking by the holder on the products concerned.

The visit may be reduced, or even abandoned, when the new site is already known by CERTITA.

The methods for assessing and deciding upon a renewal of the certification are the same as those described for admission in Part 3.

4.4.3 Modification concerning the quality organisation of the production unit

The holder shall report in writing to CERTITA any modification regarding its quality organisation that could have an impact on the conformity of production to the requirements of these certification rules (modifications regarding its facilities, quality plans, etc.).

Any certification modification of the quality management system must be declared in particular.

If internal inspection of an NF certified product is temporarily suspended, the holder must cease NF marking immediately.

In this case, CERTITA notifies a decision of suspension of the right to use the NF Mark for a certain period. If the right of use cannot be reinstated at the end of this period, it will be withdrawn.

4.4.4 Modification regarding the NF certified product

Any modification of the NF certified product with respect to the application file, the accepted model or the rules defined in the certification reference standard which is likely to have an impact on the product's conformity to the requirements of these certification rules must be subject to a written declaration to CERTITA.

CERTITA determines whether this constitutes an application to extend the certification.

4.4.5 Temporary or definitive cessation of production

Any definitive or temporary cessation of production of an NF certified product or any abandonment of the right to use the NF mark shall be declared in writing to CERTITA, specifying the period of time required to use up the stock of NF marked products. The suspension or withdrawal of the right to use the NF mark shall be notified by CERTITA.

Any temporary cessation of production of a range of NF certified products, deemed to last for too long by CERTITA, possibly after consulting the Special Committee, may, after an investigation, lead to the suspension or withdrawal of the right to use the mark for these products.

Part 5 PARTICIPANTS

The bodies involved in the procedure to grant the right to use the NF mark and to monitor the NF certified products are specified below.

AFNOR Certification ensures that all participants carry out their mission correctly with respect to their role and their attributions as defined below.

5.1 MANDATED BODY

In accordance with article 3 of the General Rules of the NF mark, AFNOR Certification entrusts the different tasks required to manage the "Heat Pump" NF Mark to the following body, called the mandated body (M.B.) :



39/41, rue louis blanc
F- 92400 COURBEVOIE

☎: + 33 1 47 17 64 85

📠: + 33 1 47 17 62 45

Site: www.certita.fr - Email: certita@certita.fr

5.2 INSPECTION BODY

The audit functions for the manufacturing unit, and possibly for the sites of use, are carried out by the following body, called the **inspection body**:



39/41, rue louis blanc
F- 92400 COURBEVOIE

☎: + 33 1 47 17 64 85

📠: + 33 1 47 17 62 45

Site: www.certita.fr - Email: certita@certita.fr



Le progrès, une passion à partager
1, rue Gaston Boissier
F-75724 PARIS CEDEX 15

☎: + 33 1 40 43 37 00

📠: + 33 1 40 43 37 37

Site: www.lne.fr - Email: info@lne.fr

The auditors are entitled to inspect the applicant's or holder's facilities, in order to perform their mission.

5.3 TEST BODY

When the inspections carried out comprise tests on products, these are performed at CERTITA's request at the following laboratory, called the **mark laboratory**:



Ctra. Villaviciosa de Odòn a Móstoles km 1.5
28935 Móstoles – MADRID – SPAIN
☎: + 34 91.616.97.10
📠: + 34 91.616.23.72
Site: www.ceis.es – Email: ceis@ceis.es



Domaine scientifique de la Doua - 25 Avenue des Arts
B.P. 2042
69603 Villeurbanne Cedex - FRANCE
☎: + 33 4.72.44.49.00
📠: + 33 4.72.44.49.49
Site: www.cetiat.fr - Email : cetiat.commercial@cetiat.fr



Le progrès, une passion à partager
29 avenue Roger Hennequin
F-78197 TRAPPES Cedex
☎: + 33 1 30 69 10 00
📠: + 33 1 30 69 12 34
Site: www.lne.fr - Email: info@lne.fr



SP Sveriges Tekniska Forskningsinstitut
SP Technical Research Institute of Sweden
Energiteknik / Energy Technology
Box 857, SE-501 15 Borås, Sweden
☎: +46 10 516 50 00,
📠: +46 33 13 19 79
Site: www.sp.se – Email: info@sp.se

5.4 SUBCONTRACTING

Possibly after consulting the Special Committee and with the agreement of AFNOR Certification, the different functions described in paragraphs 5.2 and 5.3 could be performed by other European audit bodies or laboratories, which are well known and have signed a subcontracting agreement with CERTITA.

5.5 SPECIAL COMMITTEE

In accordance with paragraph 7.3 of the general rules of NF mark, there is an advisory body called a Special Committee, whose secretariat is performed by CERTITA.

Its members are as follows:

One Chairman (member of one of the colleges stated below)

2 Vice-chairmen (one representative of AFNOR Certification and one representative of CERTITA)

MANUFACTURERS (3 to 6 representatives)

USERS/PRESCRIBERS (1 to 6 representatives)

TECHNICAL BODIES (1 to 5 representatives)

GOVERNMENT DEPARTMENTS (1 to 2 representatives)

The Committee issues decision opinions and its members are not allowed to receive any compensation for the functions they perform.

The length of the delegation period of the members is 3 years. This delegation period is renewable by tacit agreement. The Committee Chairman can change every year.

During their sessions, the Special Committee can assign certain tasks to a working group whose members must be appointed from among the members of the Special Committee and whose mission shall be defined.

Special Committee members undertake to keep personal information disclosed to them confidential. CERTITA takes the specific measures to ensure the confidentiality of applicant or holder files presented to the Committee (except in the event of disputes/appeals).

Part 6 USE OF MANUFACTURERS' LABORATORIES

This Annex describes the procedure according to which an applicant/holder may be authorised to conduct in his own laboratories all or part of the tests required for examining an application he has submitted. If the tests are performed partially, then the remaining tests are to be performed in a mark laboratory.

The appliances admitted by this procedure are subject to a systematic inspection according to article 4.2.2 in Part 4.

When the authorisation is granted, it is said that the Manufacturer has obtained an "NF Authorisation", and the laboratory(ies) involved are said to be "NF Authorised". The NF Authorisation of a laboratory applies only for the NF Mark application, and any mention of this authorisation in a different context is forbidden.

6.1 CASE OF ACCREDITED MANUFACTURERS' LABORATORIES

6.1.1 NF authorisation request

Any applicant/holder with a Laboratory approved by COFRAC or any equivalent institution recognised by the E.A (European Cooperation for Accreditation), may ask for "NF Authorisation". In this case, the NF mark admission/extension tests related to the products, made in the same laboratory and covered by this accreditation, will be considered by CERTITA.

The NF authorisation request must be sent to CERTITA, with the following attachments:

- a copy of the accreditation decision stating its limitations (type of tests concerned);
 - the report(s) drawn up by the accrediting body as part of its accreditation procedure and any subsequent reports of verifications carried out by the latter;
 - the commitment to comply with the relevant provisions of the certification rules and of its parts;
- and, by indicating for which tests the NF authorisation is required, out of those subject to the accreditation.

Prior to the NF authorisation request, a comparison between the applicant/holder's laboratory and one of the independent laboratories of the mark is carried out on the appliance.

The costs of all aforementioned operations will be borne by the applicant.

6.1.2 NF authorisation agreement

CERTITA studies the request and checks that it is complete.

CERTITA approves or rejects the NF Authorisation specifying the reasons, or delays the decision by recommending an additional investigation.

The Special Committee is informed of the authorisations granted.

6.1.3 NF authorisation validity period

The NF authorisation is valid for a maximum period of two years.

6.1.4 Verification after the NF authorisation – NF authorisation validity period

The NF authorised laboratory keeps CERTITA regularly informed of the verifications performed by COFRAC or any equivalent institution recognised by the E.A. and the decisions the latter makes after these verifications as part of its accreditation follow-up.

This information, together with the results of the verifications made under these certification rules ("systematic" and other verifications) are examined by CERTITA which, after evaluation, recommends maintaining, suspending or withdrawing the NF authorisation for all or part of the tests.

Any total or partial suspension or withdrawal of accreditation by COFRAC or any equivalent institution recognised by the E.A will lead to a new evaluation of the Laboratory status regarding the NF mark.

6.1.5 Laboratory NF authorisation renewal

The NF authorised laboratory keeps CERTITA regularly informed of the verifications performed by the accrediting body and the decisions made by the latter after said verifications concerning its accreditation renewal.

Two situations are possible at this stage:

- the laboratory has an accreditation by COFRAC or any equivalent institution recognised by the E.A for all or part of the tests subject to the expired NF authorisation.

In this case, the applicant/holder may ask for renewal of its NF authorisation for said tests according to the procedure described in 6.1, for the set time frame in this procedure.

- the accreditation from COFRAC or any equivalent institution recognised by the E.A has been withdrawn for all or part of the tests subject to the expired NF authorisation.

In this case, the applicant/holder may nevertheless ask for renewal of its NF authorisation for said tests. CERTITA gives a verdict on this renewal application, in the light of the investigation performed by COFRAC or any equivalent institution recognised by the E.A., and the reasons for refusing accreditation by COFRAC or an equivalent institution recognised by the E.A.. CERTITA lays down the conditions applying to this possible renewal, indicating the verifications to be carried out.

6.1.6 Inter-laboratory tests

Every year the accredited laboratory of an applicant/holder and one of the laboratories of the mark carry out standardised tests on 1 appliance presented for admission or sampled for this purpose. The test reports are submitted to CERTITA for a comparison of results. If anything abnormal is found, the managers of both laboratories will take the appropriate corrective actions, under CERTITA supervision.

After examining the test results, CERTITA will be able, if required, and possibly after consulting the Special Committee, to require further tests.

The costs of tests performed in the independent laboratory are borne by the applicant/holder.

CERTITA is in charge of following up these tests.

Authorisation procedure for an applicant/holder laboratory with respect to the NF mark

Holder	CERTITA	Mark laboratory
Phase 1		
<ul style="list-style-type: none"> . sends a complete application file to CERTITA, in 1 copy, according to article 1.2.1 of the present appendix. The application must also specify the name of the independent mark laboratory that the manufacturer would like to perform the comparison test of PHASE 2. 	<ul style="list-style-type: none"> records the application and verifies that it is complete, processes the application, informs the independent laboratory of the Mark that has been selected, issues the corresponding invoice to the manufacturer. 	
Phase 2		
<ul style="list-style-type: none"> . conducts the NF conformity tests, . draws up the corresponding test report, . keeps the tested equipment available for the independent mark laboratory, . sends the mark laboratory: . the test report, . documentation relating to the tested equipment . issues a test evaluation request for test comparison to the independent laboratory. 		<ul style="list-style-type: none"> . conducts the inter-comparison test, . draws up the corresponding test report, . submits the report to CERTITA and to the manufacturer issues the corresponding invoice to the manufacturer.
Phase 3		
	<ul style="list-style-type: none"> . examines the whole file (inter-comparison test results, etc.), . makes a decision based on the results notifies its decision to the manufacturer, submitting a copy to the Technical Secretariat and to the c laboratory of the mark in question. The certificate specifies the NF authorisation scope (applicable documents, complete or partial tests). 	
Phase 4		
	<ul style="list-style-type: none"> . examines the renewal procedure according to the provisions of Part 6. 	

Procedure for tests carried out by an authorised applicant/holder laboratory with respect to the NF mark (according to its authorisation scope)

Manufacturer	Mark laboratory	CERTITA
Phase 1		
<ul style="list-style-type: none"> . sends CERTITA the application for the right to use the NF Mark for its products, . in view of conducting the examination of STAGE 2, sends the mark laboratory the report of the tests conducted in its NF authorised laboratory as part of its application, in 2 copies. 		<ul style="list-style-type: none"> . gives a file number to the application . processes the application . issues the corresponding invoices (admission and report evaluation costs), . submits an original of the application to the laboratory.
Phase 2		
	<ul style="list-style-type: none"> . examines the test report submitted by the manufacturer, . makes or has carried out the modifications or supplementary information, if necessary, in agreement with CERTITA, . sends CERTITA the test report and the examination conclusions, 	<ul style="list-style-type: none"> . completes the manufacturer's application with the results sent by the mark laboratory,
Phase 3		
		<ul style="list-style-type: none"> . notifies its decision to the manufacturer according to the NF certification procedure,
Phase 4		

Part 7 RATES

Services relating to NF certification are broken down as follows:

- registration
- processing of the certification application
- operation of the certification application
- tests
- audits
- sampling
- right to use the NF mark
- additional inspections
- promotion

7.1 SERVICES RELATING TO NF CERTIFICATION

Type of service	Service definition	General conditions common to NF marks
Registration	Participation in setting up the NF mark, including drawing up the certification rules.	The registration fees are paid by the company during an initial application for the right to use the NF mark. Payment of these services will not be reimbursed, even if the right to use the NF mark is not granted or if the application is abandoned during processing.
Processing of the certification application	Services associated with examining application files, with relations with applicants, laboratories, auditors or the assessment of inspection results.	This service is invoiced as soon as the application is received. It is a flat rate. Payment of these services will not be reimbursed, even if the right to use the NF mark is not granted or if the application is abandoned during processing.
Operation of the certification application	Services for managing applications of certified products and their holders, drawing up lists of certified products, and assessing inspection results.	
Tests	Test services corresponding to laboratory rates.	The laboratories' rates are given out on request. Payment of these services will not be reimbursed, even if the right to use the NF mark is not granted or if the application is abandoned during processing

Type of service	Service definition	General conditions common to NF marks
Audit	Services involving preparation of the audit, the audit itself as well as the report. Travel expenses will be added to	Payment of these services will not be reimbursed, even if the right to use the NF mark is not granted or renewed

	these services.	
Right to use the NF mark	This right of use falling under AFNOR Certification's responsibility is intended to cover: <ul style="list-style-type: none"> - the general operation of the NF mark (placed under quality assurance, follow-up of organisations of the NF network, management of the certification committee) - defence of the NF mark: mark registration and protection, legal advice, processing appeals, legal services - contribution to the general promotion of the NF mark 	The annual rate for the right to use the NF mark is invoiced to the holder after certification of a product.
Additional inspections	Services incurred by additional inspections or verification tests that may prove necessary following inadequacies or anomalies revealed by current inspections	These services shall be paid for by the manufacturer at the current rates, distributed on request.
Promotion	Sector-based promotion actions of the NF Mark	Service for which the amount is defined every year and invoiced in addition to the services

7.2 COLLECTING PAYMENT FOR SERVICES

The registration fee and costs for the examination and inspection services invoiced as part of an application to accept or extend the right to use the mark must be paid all at once, when the application is submitted, with a view to registering it officially. They will not be reimbursed even if the right of use is not granted or extended.

The costs concerning the annual follow-up services and the right of use are issued once a year, at the beginning of the year. All applications to surrender the right to use the NF mark shall reach CERTITA by 31 December of the current year at the latest, so that the range of heat pumps is not taken into account in the following year. These costs remain payable in the event of non-renewal, cancellation or suspension of the right of use during the year.

CERTITA is in charge of transferring to AFNOR CERTIFICATION its corresponding part.

The applicant or the holder of the usage right must pay all the expenses in the following prescribed conditions: any failure on his part is in fact an obstacle to the exercise by CERTITA of the inspection and intervention responsibilities that are incumbent on it under the present regulations.

Should an initial notice, notified by recorded delivery, not determine, within one month, full payment of all the sums due, any penalty provided by in article 11 of the general rules of the NF mark may be applied for all of the holder's admitted products.

7.3 RATES

The costs are subject to a rates list distributed by CERTITA on request at the beginning of each year.

Part 8

CERTIFICATION FILES

The application for the right to use the NF Mark must be drawn up in three copies, addressed to CERTITA in accordance with the models defined below in French or English.

If the product comes from a manufacturing unit outside the European Economic Area, the applicant will appoint an authorised agent within the European Economic Area who jointly signs the application.

An application concerning a product availing of a foreign conformity mark or a test certificate issued by a foreign laboratory is processed according to existing recognition agreements, in accordance with article 8 of the general rules of the NF Mark.

NOTE:

- A copy of the conformity certificate/declaration to European directives must be attached to each application.
- Electronic versions of letter models and data sheets may be obtained from CERTITA.

8.1 CASE OF AN INITIAL CERTIFICATION APPLICATION

The applicant puts together a file according to the “**application file**” check-list:

- an application and commitment letter according to standard letter 1,

8.2 CASE OF A SUBSEQUENT APPLICATION

This application applies for a company benefiting from a right to use the Heat Pump NF mark.

The holder puts together a file according to the “**application file**” check-list, including the following specific documents:

- an application and commitment letter according to standard letter 1,

8.3 CASE OF AN APPLICATION FOR EXTENSION

The holder puts together a file according to the “**application file**” check-list, including the following specific documents:

- an application and commitment letter according to standard letter 2,

8.4 CASE OF AN APPLICATION FOR MAINTENANCE

Arrangements

The application file contains:

- an application letter according to standard letter 3 (part 1), to be filled in by the applicant/holder and signed by the distributor/beneficiary (if relevant); the distributor's commitment letter according to standard letter 3 (part 2), if the latter is not the applicant/holder of the right to use the NF mark.
- the distributor's/beneficiary's sales documentation (manual and/or extract from catalogue) relating to the products in question,
- standard sheet 1 filled in under the distributor heading

“Application File” Check-list

DOCUMENTS TO BE SUPPLIED FOR EACH RANGE	NUMBER OF COPIES
Application letter (for right to use) as specified in § 8.1 to 8.3	1
General datasheet regarding the applicant and participants according to STANDARD SHEET 1	1
Technical datasheet according to STANDARD SHEET 2	2
In case of subcontractors for some stages, as detailed in 1.1, Commitment Sheet according to STANDARD SHEET 3	1
In the case of an authorised agent, as detailed in 1.1, Commitment Sheet according to STANDARD SHEET 4	1
Wiring Diagram	1
Specifications Plate, in original or model. This must feature the NF logo marking draft. For splits and multi-splits, that of the outdoor and indoor unit.	1
Installation and user's manual, in French	1
Original tests report(s) for the appliance(s), in French and/or English	1
Summary report of the Heat Pump NF examination, issued by the test laboratory	1
Declaration of product conformity to the European directives and regulations which are applicable. According to STANDARD SHEET 5	1

STANDARD LETTER 1

"Heat Pump" NF MARK

**APPLICATION FOR THE RIGHT TO USE THE NF MARK or
SUBSEQUENT ADMISSION APPLICATION**

(to be drawn up on the applicant's *headed paper*)

Monsieur le Président de CERTITA
39 - 41, rue Louis Blanc
92 400 COURBEVOIE (FRANCE)

RE: **"Heat Pump" NF MARK**

Application for the right to use the NF mark or subsequent admission application

Attachment(s): a technical file.

Dear Sir,

I am writing to apply for the right to use the NF Mark

- for the following commercial brand: (*trade mark, trade name*).
- for the products (*reference/name of models*). The products can be described on the "standard sheet 2" technical datasheet. In this case, refer thereto)
- manufactured in the following unit(s): (*Corporate name and address, which can be described on the "standard sheet 2" technical datasheet. In this case, refer thereto*)

In this respect, I declare knowledge and acceptance of the "General rules of the NF mark", the Heat Pump – NF mark certification rules, and undertake to comply thereto during throughout the period of use of the NF mark.

<OPTION: Furthermore, I authorise the company (corporate name), (company status), (registered offices) represented by (Mr/Mrs/Miss) (name of the representative) acting as (role) to be my agent in the European Economic Area for any question referring to the use of the "Heat pump" NF Mark.*

I undertake to inform CERTITA immediately of any change in the aforementioned representative.

For such purposes, I ask that the fees incumbent on me be invoiced directly to him/her. S/he will directly pay them on my behalf upon receiving the invoices, as s/he so undertakes when accepting to be my representative.

Yours faithfully,

**Date and signature of the official representative of
applicant**

<OPTION: Date and signature of the official representative after the handwritten words "bon pour représentation"

<OPTION¹ Date and signature of the Representative in the European Economic Area after the handwritten words: ""Bon pour acceptance de la représentation">

¹ *OPTION* Only for Applicants or Holders from outside of the European Economic Space.

LETTER-TYPE 2
"Heat Pump" NF MARK

APPLICATION FOR EXTENSION OF THE RIGHT TO USE THE NF MARK

(To be drawn up on the holder's headed paper)

Monsieur le Président de CERTITA
39 - 41, rue Louis Blanc
92 400 COURBEVOIE (FRANCE)

RE: **«Heat Pump" NF mark**
Application for extension of the right to use the NF Mark

Attachment(s): a technical file.

Dear Sir,

As holder of the "Heat Pump" NF Mark for the products of my own production identified by the following references:

- trademark: ;
- trade name: ;
- designation of the product(s): *(which may be appended to the application letter)*;
- manufacturing unit(s) *(corporate name)* (address): *(which may be appended to the application letter)*;
- right of use granted on *(date)* with number: ;

I am writing to apply for the right to use the NF Mark for the products of my own production, deriving from the NF certified products with the following modifications: *(description of modifications)*.

These products, for which the extension application is made, will replace the certified products:

NO ¹

YES ¹

I hereby declare that the other features of the products concerned by this application are in strict conformity to the products that are already NF certified and manufactured in the same conditions.

Yours faithfully,

Date and signature of the applicant's official representative

<OPTION: Date and signature of the official representative after the handwritten words "bon pour représentation"

<OPTION¹ Date and signature of the Representative in the European Economic Area after the handwritten words: ""Bon pour acceptation de la représentation">

STANDARD LETTER 3 – Part 1 – Holder authorisation

¹ Delete as necessary.

OPTION¹ Only for Applicants or Holders from outside of the European Economic Space.

"Heat Pump" NF MARK
APPLICATION FOR MAINTENANCE OF THE RIGHT TO USE THE NF MARK

(To be drawn up on the holder's *headed paper*)

Monsieur le Président de CERTITA
39 - 41, rue Louis Blanc
92 400 COURBEVOIE (FRANCE)

RE: **"Heat Pump" NF MARK**

Application for maintenance of the right to use the NF mark

Dear Sir,

I am writing to apply for the maintenance to use the NF Mark on products which differ from the products approved for the mark only by their references and trademark they bear and some adjustments which do not modify their features in any way.

For the following new trademark:

Identification of the NF mark admitted		Trade name ⁽¹⁾ requested by the distributor/beneficiary		
Certificate no.	Name and reference of the manufacturer's product	Trade name	Trade name of the range	HP ref./model
xxx....				

<OPTION: The company which is going to distribute these products under the aforementioned trademark has the following details:

Name :

Address:

Please find attached a copy of the Commitment sheet of the company (distributor name) to distribute under this commercial brand (name or commercial reference) only the products that I deliver to him.

I undertake to inform CERTITA immediately of any modification made in the distribution of said products, especially of any cessation in supply to the aforementioned Company.

I authorise CERTITA to inform the aforementioned Company of any penalty applied taken in accordance with the Regulations, regarding the products covered by this application.>

Yours faithfully,

DISTRIBUTOR'S STAMP Date and signature of the official

representative of the holder, maintenance

applicant

(1) By "Trade name" is understood any distinctive sign permitting accurate identification both of the distributor and the product covered by the NF mark.

<OPTION> To be completed if the distributor/beneficiary is not holder/applicant for the right to use the NF mark.

STANDARD SHEET 1
"Heat Pump" NF MARK
GENERAL DATASHEET CONCERNING

THE APPLICANT

- Corporate name: _____
- Address: _____
- Country: _____
- Telephone: _____ Fax: _____
- SIRET no³: _____ NAF code¹: _____
- Name and position of official representative: _____
- Name and profession of the correspondent (if different): _____
- VAT ID number⁴: _____
- Email address of contact person: _____
- Email address of the Company: _____
- Website: _____
- Certified quality system: ISO 9001 (attach copy of certificate)

THE MANUFACTURER (if different from applicant/holder, above):

(Complete for each manufacturing site, including for internal units)

- Corporate name: _____
- Address: _____
- Country: _____
- Telephone: _____ Fax: _____
- SIRET No¹: _____ NAF code¹: _____
- Name and position of official representative²: _____
- Name and profession of the correspondent (if different): _____
- VAT ID number³: _____
- Email address of contact person: _____
- Email address of the Company: _____
- Website: _____
- Certified quality system: ISO 9001 (attach copy of certificate)

THE AUTHORISED AGENT or DISTRIBUTOR (if necessary):

- Corporate name: _____
- Address: _____
- Country: _____
- Telephone: _____ Fax: _____
- SIRET No¹: _____ NAF code¹: _____
- Name and position of official representative²: _____
- Name and profession of the correspondent (if different): _____
- VAT ID number³: _____
- Email address of contact person: _____
- Email address of the Company: _____
- Website: _____

1 Only for French companies.
2 The legal representative is the person legally responsible.
3 This is concerning European manufacturers.

STANDARD SHEET 2

TECHNICAL DATASHEET

NB: ONE sheet must be completed per heat pump range

1 – DEFINITION OF THE USE OF THE HP COVERED BY THE APPLICATION

- "Space heating" HP
 - with "cooling" option

- "Swimming pool" HP

- "Space heating" HP and "swimming pool" HP

2 – DESCRIPTION OF THE HEAT PUMP

Identification of products:

 **Be very exact in identifying the products below. These identifications will be restated word for word on the admission certificate.**

- Trademark:

- Commercial brand (*group name (range) of heat pumps*):
.....

- Model names or references:
.....
.....

- References or names for monosplits or multi-splits:
(If necessary, fill in per type (wall, bracket, etc) and each component (inner units))
.....
.....
.....

Assembly unit(s):

 To be filled in for each manufacturing site that produces machines covered by the application (packages, outdoor unit, indoor unit)

Name of the machine or units	Corporate name and address of manufacturing site
➤
➤

NB: Reproduce as many times as necessary

Type of heat pump subject to the application: (tick the relevant box(es))

Outdoor air/Recycled air HP – single-unit

- ductless indoor installation
- ducted indoor installation
- ducted outdoor installation

Exhaust air/Fresh air HP – single-unit

- ducted indoor installation
- ducted suction indoor installation

Exhaust air/Water HP – single-unit

- ducted indoor installation
- ducted indoor suction.....
- ducted indoor discharge

Outdoor air/Recycled air HP – single-split

- unducted
- ducted

Outdoor air/Recycled air HP - multi-split

- unducted
- ducted

Outdoor air/Water HP – single-unit

- unducted outdoor installation
- ducted indoor installation

Outdoor air/Water HP - split

- unducted outdoor installation
- ducted indoor installation

- Outdoor air/Water HP – single-unit
 - unducted outdoor installation
 - ducted indoor installation
- Outdoor air/Ground HP – split
- Glycol water/Water HP – single unit
 - outdoor installation
 - indoor installation
- Glycol water/Water HP - split
- Glycol water/Glycol water HP – single unit
 - outdoor installation
 - indoor installation
- Glycol water/Glycol water HP – split
- Ground water/Water HP – single unit
 - outdoor installation
 - indoor installation
 - With barrier exchanger
 - Without barrier exchanger
- Ground water/Water HP – split
- Groundwater/Recycled air HP – single-unit
- Groundwater/Recycled air HP – split
- Ground water/Ground HP – single unit
- Ground water/Ground HP – split
- Water circuit/Recycled air HP
 - unducted
 - ducted
- Ground/Ground HP
 - outdoor installation
 - indoor installation
- Ground/Water HP
 - outdoor installation
 - indoor installation

2 – INFORMATION ON THE HEAT PUMP AND/OR ITS VARIOUS SEPARATE COMPONENTS

✓ **Heat pump installation site (*tick the relevant box*):**

Outdoors Indoors

Note, for splits and multi-splits:

The components are considered to be separate by definition. One part outdoors and the other part indoors. Please specify locations if this is not the case.

.....
.....

✓ Defrosting (principle):

.....

✓ Regulation (principle):

.....

✓ **Setting condition** of the HP for the requested applications (for: Inverter, Expansion valve, Defrost, Other), if applicable:

.....
.....
.....

Do settings require work by the applicant? YES NO

✓ **Continuously variable capacity HP**

Declared control change threshold $L_{rcontmin}$:... *(in the table of characteristics below)*

Declared performance correction coefficient $C_{cpLrcontmin}$: *(in the table of characteristics below)*

Declared ratio:..... *(in the table of characteristics below)*

Declared residual capacity:..... *(in the table of characteristics below)*

Declared auxiliary power: *(in the table of characteristics below)*

✓ **Acoustic:** if applicable, specific installation conditions for the HP

✓ **Pressure on the air** for appliances with ducting: *(give value)*

- ✓ Heat pump equipment (*tick the relevant box(es)*)
 - Variable speed compressor (DC, Inverter, etc ...)
 - Multiple speed fan. Number:
 - Variable speed fan
 - Expansion valve with type (thermostatic, electronic, ...)
 - Exchanger cooling operation (free cooling)
 - Heater
 - Domestic hot water production included in the HP
 - Other equipment or accessories:

.....
.....

If the equipment mentioned below is not installed on all the models, it must be subject to separate right of use applications. However, we invite you to contact CERTITA to confirm this.

- Reversible cycle cooling operation (*reversible heat pump*)
- Passive cooling mode operation
- Circulation pump for collectors
 - Multiple speed circulation pump. Number:
 - Variable speed pump
- Circulation pump for the heating circuit
 - Multiple speed circulation pump. Number:
 - Variable speed pump
- Accumulator (buffer tank)

✓ **requested operating points:**

Depending on the HP categories covered by the application (heating and reversible if appropriate, swimming pools), the requested operating point shall be detailed in the data and characteristics tables given below.

✓ **Starting point at -15°C:**

For Outdoor Air – Water type heat pumps, an HP starting point must be carried out to validate the operating range. To enable the laboratory to conduct the test, we ask that you specify below the maximum water temperature, for an outdoor temperature of -15°C. This value will be restated on the NF mark admission decision for the range.

Maximum water temperature = °C

Specific information about "swimming pool" HPs (to be completed if covered by the application)

✓ **Water flow** in the swimming pool exchanger (*tick the relevant box*):

Low flow (temperature condition 26 - 31°C - $\Delta T = 5^{\circ}K$)

High flow (temperature condition 26 – 28 °C - $\Delta T = 2^{\circ}K$)

✓ **Use** requested for Air/Swimming pool water type HPs (*tick the relevant box*).

Seasonal use (2 test conditions: 7°C and 15°C Air)

Annual use (3 test conditions: 2°C, 7°C and 15°C Air)

3 – MAIN COMPONENTS OF THE HEAT PUMP

	HP no. 1		HP no. 2		HP no.	
	Circuit no. 1	Circuit no. 2	Circuit no. 1	Circuit no. 2	Circuit no. 1	Circuit no. 2
Reference / model						
Liquid refrigerant						
Type						
Load (kg)						
Compressor						
Type (Piston, Scroll, etc.)						
Trade name						
Model						
Number						
Phase shift condenser						
Features						
Expansion device						
Type						
Manufacturer						
Model						
<u>Liquid receiver</u>						
Volume (in l)						

FOR THE OUTDOOR EXCHANGER - WATER

(Fill in if covered)

	HP no. 1		HP no. 2		HP no.	
	Circuit no. 1	Circuit no. 2	Circuit no. 1	Circuit no. 2	Circuit no. 1	Circuit no. 2
Reference / model <i>(only for separate components of the HP)</i>						
Exchanger(s)						
Type						
Manufacturer						
Model						
Number						
Integrated pump "YES or NO"						
Manufacturer						
Model						
Number						
Setting position (if several positions)						
Glycol-water mix type and concentration						

FOR THE OUTDOOR EXCHANGER - AIR

(Fill in if covered)

	HP no. 1		HP no. 2		HP no.	
	Circuit no. 1	Circuit no. 2	Circuit no. 1	Circuit no. 2	Circuit no. 1	Circuit no. 2
Reference / model <i>(only for separate components from the HP)</i>						
Exchanger(s)						
Type						
Manufacturer						
Model						
Front area (m2)						
Fins type/spacing (in mm)						
Fan(s)						
Type						
Number						
Trade name						
Rotation speed (rev/min)						
Diameter of blades or turbine (mm)						
Number of blades/turbines						
Fan motor(s)						
Manufacturer						
Reference						

FOR OUTDOOR EXCHANGER for Ground/Water or Ground/Ground type heat pump) - **GROUND**

(Fill in if covered)

	HP no. 1		HP no. 2		HP no.	
	Circuit no. 1	Circuit no. 2	Circuit no. 1	Circuit no. 2	Circuit no. 1	Circuit no. 2
Crowns						
Type						
Manufacturer						
Model						
Number						
External diameter (in mm)						
Thickness (mm)						
Length of a crown (in m)						
Materials						

FOR THE INDOOR EXCHANGER - WATER						
<i>(Fill in if covered)</i>						
	HP no. 1		HP no. 2		HP no.	
	Circuit no. 1	Circuit no. 2	Circuit no. 1	Circuit no. 2	Circuit no. 1	Circuit no. 2
Reference / model <i>(only for separate components from the HP)</i>						
Exchanger						
Type						
Manufacturer						
Model						
Number						
Integrated pump "YES or NO"						
Manufacturer						
Model						
Number						
Set position (if several positions)						
Glycol water type and concentration						

FOR THE INDOOR EXCHANGER - AIR						
<i>(Fill in if covered)</i>						
	HP no. 1		HP no. 2		HP no.	
	Circuit no. 1	Circuit no. 2	Circuit no. 1	Circuit no. 2	Circuit no. 1	Circuit no. 2
Reference / model <i>(only for separate components from the HP)</i>						
Exchanger						
Type						
Manufacturer						
Model						
Front area (m2)						
Fins type/spacing (in mm)						
Fan(s)						
Number						
Trade name						
Type						
Rotation speed (rev/min)						
Diameter of blades or turbine (mm)						
Number of blades/turbines						
Motor						
Manufacturer						
Reference						

FOR INDOOR EXCHANGER (for Ground/Water or Air/Ground type heat pump) - GROUND

(Fill in if covered)

	HP no. 1		HP no. 2		HP no.	
	Circuit no. 1	Circuit no. 2	Circuit no. 1	Circuit no. 2	Circuit no. 1	Circuit no. 2
Crowns						
Type						
Manufacturer						
Number						
External diameter (in mm)						
Length of a crown (in m)						
Thickness (mm)						
Thickness (mm)						
Materials						

FOR THE SWIMMING POOL EXCHANGER

(Fill in if covered)

	HP no. 1		HP no. 2		HP no.	
	Circuit no. 1	Circuit no. 2	Circuit no. 1	Circuit no. 2	Circuit no. 1	Circuit no. 2
Reference / model <i>(only for separate components from the HP)</i>						
Exchanger						
Type						
Manufacturer						
Model						
Number						
Integrated pump "YES or NO" <i>(for heating + swimming pool exchanger HPs)</i>						
Manufacturer						
Model						
Number						
Set position (if several positions)						
Glycol water type and concentration						

4 – DATA AND CERTIFIED FEATURES FOR SINGLE UNITS AND MONOSPLITS

 For joint applications for "space heating" HPs and "swimming pool" HPs, fill in the table below for each of the two functions.

Characteristics for heating applications	HP No.1	HP No.2	HP No.3	HP No.....	HP No.....
Reference/Model of the heat pump or combination:					
- Reference of outdoor unit					
- Reference of indoor unit					
Nominal voltage (in V)					
Current type (~ 50 Hz or 3~ 50Hz or 3 N~50 Hz)					
If applicable					
Regulation changeover threshold LRcontmin					
Performance correction coefficient CcpLRcontmin					
Ratio					
Residual power					
Auxiliary power					
Temperature conditions/.....°C					
Heating capacity (in kW)					
Absorbed power (in kW)					
COP (stated with 3 significant figures)					
Temperature conditions/.....°C					
Heating capacity (in kW)					
Absorbed power (in kW)					
COP (stated with 3 significant figures)					
Temperature conditions/.....°C					
Heating capacity (in kW)					
Absorbed power (in kW)					
COP (stated with 3 significant figures)					
Sound power (in dB(A), stated in 1/10 th) in the temperature conditions →/.....°C for: (see test diagrams)					
Outdoor side, , noise radiated by the casing					
Outdoor side, global noise of openings					
Indoor side, noise radiated by the casing					
Indoor side, airborne noise in the suction ducts					
Indoor side, airborne noise in the discharge ducts					
Indoor side, airborne noise in the suction inlet and radiated noise by the casing					

Characteristics for cooling applications	HP No.1	HP No.2	HP No.3	HP No.....	HP No.....
Reference/Model of the heat pump or combination:					
- Reference of outdoor unit					
- Reference of indoor unit					
Nominal voltage (in V)					
Current type (~ 50 Hz or 3~ 50Hz or 3 N~50 Hz)					
Temperature conditions_...../....._.....°C					
Cooling capacity (in kW)					
Absorbed power (in kW)					
EER (stated with 3 significant figures)					
Temperature conditions_...../....._.....°C					
Cooling capacity (in kW)					
Absorbed power (in kW)					
EER (stated with 3 significant figures)					
Temperature conditions_...../....._.....°C					
Cooling capacity (in kW)					
Absorbed power (in kW)					
EER (stated with 3 significant figures)					
Temperature conditions_...../....._.....°C					
Cooling capacity (in kW)					
Absorbed power (in kW)					
EER (stated with 3 significant figures)					

4.1 – DATA AND CERTIFIED FEATURES FOR MULTISPLIT HEAT PUMPS

 **Applies to “domestic heating” HPs only**

For the outdoor unit (O.U) (Use one table per outdoor unit which is subject to the right of use application)							
Reference / Model	Nominal voltage (in V)	Current type (~ 50 Hz or 3~ 50Hz or 3 N~50 Hz)			Sound power (in dB(A), stated in 1/10 th) Radiated noise (maximum)		
Combinations by size of outdoor units (O.U)	Ratio in % (OU power with those of IU in operation)	Heating capacity (kW) at 7/6_20/15°C	Absorbed power (kW) at 7/6_20/15°C	COP	Heating capacity (kW) at -7/-8_20/15°C	Absorbed power (kW) at -7/-8_20/15°C	COP
<i>e.g.: A+A</i>							
↓							
<i>to</i>							
↓							
<i>D+E</i>							
<i>A+A+A</i>							
↓							
<i>to</i>							
↓							
<i>A+C+D</i>							
<i>A+A+A+A</i>							
↓							
<i>to</i>							
↓							
<i>B+B+B+C</i>							

4.2 - CERTIFIED SOUND POWERS FOR MULTISPLIT HEAT PUMPS

The sound power tables (in dB(A), stated in 1/10th) need filling in for each type and for all models (see test diagrams in Part 10 of these rules).

Indoor unit – Wall-mounted	Sound power	
	Noise radiated by the casing	
Reference/ Model	Low speed (1)	High speed
	(1)	
	(1)	
	(1)	
	(1)	

(1) Optional measurement. To be completed if the applicant / holder wants to certify the noise at low speed.

Indoor unit - Bracket mounted	Sound power	
	Noise radiated by the casing	
Reference/ Model	Low speed (1)	High speed
	(1)	
	(1)	
	(1)	
	(1)	

(1) Optional measurement. To be completed if the applicant / holder wants to certify the noise at low speed.

Indoor unit – Ceiling-mounted	Sound power	
	Noise radiated by the casing	
Reference/ Model	Low speed (1)	High speed
	(1)	
	(1)	
	(1)	
	(1)	

(1) Optional measurement. To be completed if the applicant / holder wants to certify the noise at low speed.

Indoor unit – With duct At suction and discharge	Sound power	
	Airborne noise in the suction duct and noise radiated by the casing	
Reference/ Model	Low speed (1)	High speed
	(1)	
	(1)	
	(1)	
	(1)	

(1) Optional measurement. To be completed if the applicant / holder wants to certify the noise at low speed.

 So that the laboratory can measure the sound power radiated by each indoor unit, the applicant must supply it with the procedure enabling operation in ventilation mode alone, without starting up the refrigeration circuit of the outdoor unit."

STANDARD SHEET 3

Heat Pump – NF MARK

Commitment for subcontracting production

This sheet is provided to define the contractual links that exist between the applicant/holder and each subcontractor to which he has subcontracted one or more requirements that cover the following stages: design, manufacture (with the exception of heat pump components), assembly, inspections, marking and packing.

This sheet must be updated whenever the contract or subcontractor changes. *A copy is then sent to CERTITA.*

Applicant / Holder:

Subcontractor:

Service identification:

(Specify depending on the definition of the applicant/holder)

Minimum requirements which must be shown in the contract:

- the subcontractor must undertake to comply with the requirements of the "Heat Pump" NF certification rules that concern him
- management of customer complaints by the applicant/holder together with the subcontractor
- management of inter-subcontractor complaints by the applicant/holder
- regarding design, the intellectual property holder must be named; he must inform the other party of any change in the design plans
- the subcontractor must inform the applicant/holder of any change in its quality management system, any temporary production stoppage, any production transfer and above all inform him of nonconformities detected during internal inspections or external audits.
- the subcontractor accepts the possible presence of a representative of the applicant/holder during the NF certification admission and monitoring audits. He also accepts that an audit may be made by the applicant/holder to ensure compliance with the NF heat pump application certification rules.

- The subcontractor must set up measures to guarantee the availability of spare parts for a 10-year period after the product has been taken off the market.

DOCUMENTS TO BE PROVIDED:

A copy of the contract in French or English.

"I certify that the minimum subcontracting requirements, above, are restated in the contract"

Date and signature of the applicant's official representative

Contract Number/Reference:

Sheet drawn up on:

Modification dates:	Subject of modification
1 -	
2 -	
3 - ...	

STANDARD SHEET 4

Heat Pump – NF MARK

Identification of the authorised agent's responsibilities

Applicant / Holder:

Authorised agent:.....

Minimum requirements which must be shown in the contract:

- assignments and associated responsibilities
- financial aspects
- complaints
- certifying body contact
- ...

Contract Number/Reference:

DOCUMENTS TO BE PROVIDED:

A copy of the contract in French or English.

Sheet drawn up on:

Modification dates:

Subject of modification

1 –

2 –

3 –

Co-signature

Part 9 Additional specifications

Appendix A SPECIFIC REQUIREMENTS FOR ELECTRICALLY DRIVEN HPs

Appendix B SPECIFIC REQUIREMENTS FOR SWIMMING POOL HPs

Part 10 Specific test methods

Appendix AA ACOUSTIC TESTS

Appendix BB GROUND – GROUND HP TESTS

Appendix CC GROUND – WATER HP TESTS

Appendix DD OUTDOOR AIR – GROUND HP TESTS

CERTIFICATION REFERENCE

HEAT PUMP – NF MARK

PART 9 – APPENDIX A

SPECIFIC PROVISIONS FOR ELECTRIC HP SPACE HEATING AND COOLING

CONTENTS

- A.1 Applicability**
- A.2 Reference documents**
- A.3 Definition of systems and ranges**
- A.4 Technical specifications and characterisation methods**
- A.5 Quality control specifications**

A.1. A.1 APPLICABILITY

This part of the NF HP reference defines the specific provisions for electric motor driven heat pumps for heating premises, including machines having a cooling function (reversible).

The cooling function can only be certified with the space heating function.

The certified characteristics are:

- The Coefficient of Performance (COP),
- The heating power,
- The absorbed electrical power,
- The acoustic power level.

The following characteristics can be optionally certified:

- The particular characteristics of variable power regulation HPs:
 - The minimum continuous operation Load Ratio ($LR_{contmin}$),
 - The COP at $LR_{contmin}$.
 - The performance correction coefficient at $LR_{contmin}$ ($C_{cpLRcontmin}$),
- The share of electrical power for the auxiliaries (Ratio).

Additionally, for the cooling function the following characteristics can also be certified:

- The Energy Efficiency Ratio (EER),
- The cooling power.

The products covered are defined according to the following types:

- "outdoor air/recycled air" type,
- "exhaust air/new air" type,
- "outdoor air/water" type,
- "exhaust air/water" type,
- "(ground)water/recycled air" type,
- "water (loop)/recycled air" type,
- "glycol-water/water mix or glycol-water",
- "(ground)water/water" type,
- "ground/ground" type,
- "ground/water" type,
- "water/ground" type,
- "outdoor air/ground" type.

A.2. REFERENCE DOCUMENTS:

The standards mentioned in §2.2.2 are completed by the following:

NF EN 14511-1 (December 2011): Air conditioners, liquid chilling packages and heat pumps with electrically driven compressors for space heating and cooling – Part 1: "Terms and definitions".

NF EN 14511-2 (December 2011): Air conditioners, liquid chilling packages and heat pumps with electrically driven compressors for space heating and cooling – Part 2: "Test conditions".

NF EN 14511-3 (December 2011): Air conditioners, liquid chilling packages and heat pumps with electrically driven compressors for space heating and cooling – Part 3: "Test methods".

NF EN 14511-4 (December 2011): Air conditioners, liquid chilling packages and heat pumps with electrically driven compressors for space heating and cooling – Part 4: "Requirements".

NF EN 15879-1 (April 2011): Testing and rating of direct exchange ground coupled heat pumps with electrically driven compressors for space heating and/or cooling - Part 1: Direct exchange-to-water heat pumps.

Pr NF EN 14825 (October 2011): Air conditioners, liquid chilling packages and heat pumps with electrically driven compressors for space heating and cooling – Testing and rating at part load conditions.

A.3. DEFINITION OF SYSTEMS AND RANGES

A heat pump range comprises products with the same components, namely:

- same refrigeration process (for example, number of compressors or stages, etc.)
- same refrigerant
- same compressor type
- same expansion valve type
- same evaporator type
- same condenser type
- same defrost principle (4-way valve or vapour injector)
- same power regulation principle (refrigerant performance management)

For a split or multi-split range, the outdoor unit is characterised by the aforementioned components and the inner units by the following components:

- same condenser type
- same fan type
- same expansion valve type (if included in the inner unit)
- same return and discharge section geometries
- same regulation principle
- same casing type
- same assembly type (apron wall, wall, ceiling, etc.).

Only combinations (of the outdoor unit and indoor unit(s)) reaching a heating capacity in the range of 80 to 120% of the outdoor unit's heating capacity during operation may be admitted for the NF mark.

Special case:

- For technological reasons, it can prove necessary to change compressor technology within a range. One or two products may therefore be added.
- A single product that exists with single-phase and three-phase power supply constitutes two models in the same range. In this case, it must be possible to distinguish between them by their names.
- For heat pumps that can be installed (as they are or with optional equipment) inside or outside, these will be viewed as two product ranges but a single heating capacity measurement will be carried out if the pressure in the duct is less than 25 Pa and two heating capacity measurements will be carried out if the pressure in the duct is greater than 25 Pa (see special test conditions in § A.4)
- For a range of appliances offering options incorporated into the heat pump, these constitute different ranges if such options have an impact on the certified features of the heat pump. In this case, the applicant shall complete separate applications for the right to use the NF mark.

- A heat pump range with reversible (heating and cooling) and standard versions (heating only) and whose commercial references or brands are different (from one version to the next) is considered to comprise two ranges. Tests shall be performed according to the following cases:
 - a- The certified features stated in the applications are the same for both versions; only the product(s) in the reversible version is (are) submitted for testing.
 - b- The certified features stated in the applications are different for both versions; the products in each version are then submitted for testing.

NB:

Should both versions have the same commercial references or brands and the same stated certified features, they will be considered to make up the same range. Tests shall be carried out on the reversible version.

A.4. TECHNICAL SPECIFICATIONS AND CHARACTERISATION METHODS

Principles:

- The thermal and acoustic performance declarations are verified by specific tests,
- COP thresholds are set for certain operating points,
- Acoustic power thresholds are set for certain HP heating capacity levels,
- Cold starting is envisaged for certain HP types.

Operating ranges:

The operating ranges for each HP are declared by the applicant / holder and can be in whole or in part (for example an operating point) performance matrices given below and taken from RT 2012 as appropriate. The matrix lines declared by the applicant / holder (corresponding to the HP operating points) do not necessarily include the RT 2012 pivot point.

However, as a minimum for the heating function, a certified point must correspond to an operating point with a COP threshold defined in the matrices below.

Intermediate operating points (corresponding to intermediate columns of the matrices) relative to those provided by the performance matrices below can be declared for certification.

The lower upstream temperature limit is set at -15°C for outdoor air.

Operating points at temperatures greater than those provided by the performance matrices below can be declared.

Note 1: as a reminder, if the pivot value is not certified, the certified characteristics cannot be validated under RT 2012.

Note 2: the optional individual characteristics of variable regulation HPs are preferably determined at the pivot point.

Note 3: when requested the share of electrical power for the auxiliaries is preferably measured at the pivot point.

Test programme:

The test programme is defined for each case according to the HP type and declared operating range so as:

- To be able to verify the characteristics at the RT 2012 matrix pivot point if appropriate,
- To permit the selection by CERTITA of at least 1 operating point,
- To take account of any specific justified requests from the applicant.

The selection of the number of products to be tested in a range is defined in § 3.1.3.2.

The number of tests to be performed to certify the desired points of the performance matrix is a function of the number of downstream temperatures declared:

- For air/water HPs: 3 tests for a declared line and 1 test per additional line,
- For other HP types: 2 tests for a declared line and 1 test per additional line.

Note 1: when an applicant declares a number of operating points less than or equal to the number of tests to be performed, the number of tests to be performed is equal to the number of points declared (the applicant can for example request 1 operating point for certification, 1 test will be done at the declared operating point).

Note 2: for certain HP types, the 14511 standards require tests to be done for certain operating points, notably to define the reference flow rates. Consequently the test programme is defined with this requirement.

If appropriate, the individual characteristics of variable power regulation HPs are determined at 1 operating point, at the pivot point conditions if declared.

If appropriate, the share of electrical power for auxiliaries is determined at 1 operating point, at the pivot point conditions if declared.

Conditions for validation of declared values for heating capacities:

If the declared values comply with the measured values taking the applicable tolerances into account, they are validated.

The applicable tolerances on the declared values are defined as follows:

- 5% on the absorbed powers,
- 5%, for the heating capacities measured for water and the corresponding COP or EER,
- 5% for heating capacities for air measured in steady state by the room calorimeter method and the corresponding COP or EER,
- 10% for heating capacities for air measured in transient regime (defrosting cycles) by the room calorimeter method and the corresponding COP or EER,
- 10% for heating capacities for air measured by the enthalpy method for air and the corresponding COP or EER,
- 10%, for heating capacities and for ground-ground, air-ground and water-ground HPs and the corresponding COP or EER.

If the declared values do not comply with the measured values, they are reset to the measured values, corrected by the applicable tolerance.

For values corresponding to unmeasured points, the declared values are corrected by a value equal to the mean differences relative to the compliance thresholds; this mean is calculated solely from the non-compliant measured values (see example below).

Example of validation of declared values

Air/water HP Comparison between declared and measured powers (kW)										
Downstream temperature (°C)		Upstream temperature (air side) (°C)								
T flow (°C)	T return (°C)	-7			2			7		
		Declared	Measured	Difference (%)	Declared	Measured	Difference	Declared	Measured	Difference (%)
35	30	4.20	4.00	4.8	3.40			7.20	6.60	8.3
45	40	4.00	3.70	7.5	2.80	2.50	10.7	7.40		

Tolerance on Powers = 5%

Processing of values:

- Measured values compliant: 4.0 → validated value = declared value = 4.2
- Measured values non-compliant: validated value = measured value x 1.05
- Unmeasured values: validated value = Declared value corrected by the mean of the relative differences with respect to the compliance thresholds, mean calculated from non-compliant values only.
- Mean relative differences with respect to compliance thresholds: $(3.3+2.5+5.7)/3 = 3.8 \%$

New corrected matrix:

Downstream temperature (°C)		Upstream temperature (air side) (°C)								
T flow (°C)	T return (°C)	-7			2			7		
		Declared	Measured	Validated	Declared	Measured	Validated	Declared	Measured	Validated
35	30	4.20	4.00	4.20	3.40		3.30	7.20	6.60	6.90
45	40	4.00	3.70	3.90	2.80	2.50	2.60	7.40		7.10

Special test conditions:

For heat pumps with continuous variable capacity control (inverter compressor or other type of power variation), the manufacturer must provide the laboratory with the corresponding setting procedure for obtaining the declared operating points.

During the different heating capacity measurement tests, the supply voltage frequencies and/or speeds are noted for compressors and fans and mentioned in the test report.

For HPs with air connections, the connection specifications defined for the sound tests (see Appendix AA) also apply to thermal tests, meaning use of the same connection ducts.

For a heat pump range that can be installed (as it is or with optional equipment) indoors or outdoors, whose pressure in the discharge duct (towards the outside) is less than 25 Pa; the heating capacity measurement tests are conducted in the outdoor free air blowing configuration with a pressure equal to 0.

"Ground – ground, "water – ground" and "outdoor air – ground" heat pumps are not part of the field of application of a standard for the determination of the heating performance of heat pumps.

This exclusion is related to the test method which is very different from those described in the European standard and applicable for heat pumps using air and water as heat transfer fluids.

Pending the preparation and publication of a European standard for these special appliances (CEN TC113 WG10 work), specific test protocols are applied for the certification of these heat pumps with respect to the heat pump NF mark and are given in:

- Appendix BB, part 10 for ground-ground HPs,
- Appendix CC, part 10 for water-ground HPs,
- Appendix DD, part 10 for outdoor air-ground HPs.

A.4.1 Energy performance in heating mode

The energy performance in heating mode, meaning the heating capacity, the absorbed electrical power and the COP, must be determined under the conditions below. COP thresholds are defined for certain operating points and must be respected.

The corresponding COP matrices appear in the § below for each HP type with the following conventions:

- When a COP value is explicitly mentioned, defines the applicable threshold for the corresponding operating point,
- The matrix elements highlighted in yellow correspond to any pivot points defined in RT 2012.

A.4.1.1 Outdoor air – water HP

The heat pump must be started up by taking an outdoor temperature of -15°C and a maximum water temperature provided by the manufacturer. The water flow rate used for the test is the one that corresponds to the first application requested and should preferably be at the pivot point.

For single-unit heat pumps installed indoors or for the indoor unit of split HPs, the indoor environment is at ambient temperature.

The HP must be able to start and operate for 20 minutes.

		T upstream (outdoor air) (°C)									
		-15	-7	2	7	20					
T downstream (water) (°C)											
T flow	T return (*)										
25	22							2.50		4.10	
35	30							2.10		3.40	
45	40							1.60		2.70	
55	47							1.30		2.20	
65	55		1.20		1.90						

(*): For an upstream temperature of 7 °C. For any other source upstream temperature, the test is performed with the nominal flow rate obtained during the 7 °C test.

A.4.1.2 Outdoor air – recycled air HP

The heat pump must be started up to validate the operating range by taking an outdoor temperature of -15°C and an indoor temperature of 15°C.

The HP must be able to start and operate for 20 minutes.

	T upstream (outdoor air) (°C)								
	-15	-7	2	7	20				
T downstream (recycled air) (°C)									
5									
10									
15									
20						2.00		3.40	
25									

A.4.1.3 Extracted air – fresh air HP

		T upstream (extracted air) (°C)				
		5	10	15	20	25
T downstream (fresh air) (°C)						
-15						
-7				2.80		
2						
7				2.30		
20						

A.4.1.4 ground water – water HP

		T upstream (ground water) (°C)			
		5	10	15	20
T return					
T flow		(**)	7	(**)	(**)
T downstream (water) (°C)					
T flow	T return (*)				
25	22		5.40		
35	30		4.50		
45	40		3.50		
55	47		2.80		
65	55		2.50		

(*): For an upstream temperature of 10-7 °C. For any other upstream source temperature, the test is performed with the nominal downstream source flow rate obtained during the 10-7 °C test.

(**) The nominal flow rate for the upstream source obtained during the 10-7 °C test is retained for the tests at other upstream source temperatures.

A.4.1.5 Glycol water – water or glycol water – glycol water HP

		T upstream (glycol water) (°C)				
		-5	0	5	10	15
T return						
T flow		(**)	-3	(**)	(**)	(**)
T downstream (water or glycol water) (°C)						
T flow	T return (*)					
25	22		4.30			
35	30		3.60			
45	40		2.80			
55	47		2.20			
65	55		1.90			

(*): For an upstream temperature of 0-(-3) °C. For any other temperature of the upstream source, the test is performed with the nominal flow rate for the downstream source obtained during the test at 0-(-3) °C.

(**) The nominal flow rate for the upstream source obtained during the 0-(-3) °C test is retained for the tests at other upstream source temperatures.

A.4.1.6 Ground water – recycled air HP

T return T flow	T upstream (ground water) (°C)			
	5	10	15	20
	(*)	7	(*)	(*)
T downstream (recycled air) (°C)				
5				
10				
15				
20			3.3	
25				

(*) The nominal flow rate for the upstream source obtained during the 10-7 °C test is retained for the tests at other upstream source temperatures.

A.4.1.7 Water circuit – recycled air HP

T return T flow	T upstream (circuit water) (°C)				
	10	15	20	25	27
	(*)	(*)	17	(*)	(*)
T downstream (recycled air) (°C)					
5					
10					
15					
20			3.3		
25					

(*) The nominal flow rate for the upstream source obtained during the 20-17 °C test is retained for the tests at other upstream source temperatures.

A.4.1.8 Glycol water – recycled air HP

T return T flow	T upstream (glycol water) (°C)				
	-5	0	5	10	15
	(*)	-3	(*)	(*)	(*)
T downstream (recycled air) (°C)					
5					
10					
15					
20		3.3			
25					

(**) The nominal flow rate for the upstream source obtained during the 0-(-3) °C test is retained for the tests at other upstream source temperatures.

A.4.1.9 Extracted air – water HP

		T upstream (extracted air) (°C)									
		5	10	15	20	25					
T downstream (water) (°C)											
T flow	T return (*)										
25	22									4.00	
35	30									3.30	
45	40									2.70	
55	47									2.20	
65	55				1.90						

(*): For an upstream temperature of 20 °C. For any other source upstream temperature, the test is performed with the nominal flow rate obtained during the 20 °C test.

A.4.1.10 Ground - water HP

		T upstream (ground) (°C) (**)	
		4	
T downstream (water) (°C)			
T flow	T return (*)		
25	22		4.10
35	30		3.40
45	40		2.70
55	47		2.20
65	55	1.90	

(*): For an upstream temperature of 4 °C. For any other source upstream temperature, the test is performed with the nominal flow rate obtained during the 4 °C test.

(**): Corresponds to the temperature of the bath glycol water

A.4.1.11 Ground - ground HP

		T upstream (ground) (°C) (*)
		-5
T downstream (ground) (°C) (**)		
35		

(*): Corresponds to the evaporation temperature

(**): Corresponds to the condensation temperature

A.4.1.12 Water - ground HP

		T upstream (water) (°C)			
		5	10	15	20
T return	T flow	(*)	7	(*)	(*)
T downstream (ground) (°C) (**)					
35					

(*): The nominal flow rate for the upstream source obtained during the 10-7 °C test is retained for the tests at other upstream source temperatures.

(**): Corresponds to the condensation temperature

A.4.1.13 Outdoor air – ground HP

The heat pump must be started up to validate the operating range by taking an outdoor temperature of -15°C and an indoor temperature of 15°C.

The HP must be able to start and operate for 20 minutes.

		T upstream (outdoor air) (°C)				
		-15	-7	2	7	20
T downstream (ground) (°C) (*)						
35			2.00		3.30	

(*): Corresponds to the condensation temperature

A.4.1 Energy performance in cooling mode

The energy performance in cooling mode, meaning the cooling capacity, and the EER, must be determined under the conditions below. There is no defined EER threshold.

The corresponding EER matrices appear in the § below for each HP type. The matrix elements highlighted in yellow correspond to any pivot points defined in RT 2012.

A.4.2.1 Outdoor air – water HP

		T upstream (outdoor air) (°C)				
		5	15	25	35	45
T downstream (water) (°C)						
T flow	T return (*)					
1.5	6.5					
7	12					
12.5	17.5					
18	23					
23.5	28.5					

(*): For an upstream temperature of 35 °C. For any other source upstream temperature, the test is performed with the nominal flow rate obtained during the 35 °C test.

A.4.2.2 Outdoor air – recycled air HP

		T upstream (outdoor air) (°C)				
		5	15	25	35	45
T downstream (recycled air) (°C)						
22						
27						
32						
37						

A.4.2.3 Extracted air – fresh air HP

		T upstream (extracted air) (°C)			
		22	27	32	37
T downstream (fresh air) (°C)					
T flow	T return (*)				
5					
15					
25					
35					
45					

A.4.2.4 Ground water – water HP

		T upstream (ground water) (°C)			
		5	10	15	20
T downstream (water) (°C)					
T flow	T return (*)	(**)	15	(**)	(**)
1.5	6.5				
7	12				
12.5	17.5				
18	23				
23.5	28.5				

(*): For an upstream temperature of 10-15 °C. For any other upstream source temperature, the test is performed with the nominal downstream source flow rate obtained during the 10-15 °C test.

(**) The nominal flow rate for the upstream source obtained during the 10-15 °C test is retained for the tests at other upstream source temperatures.

A.4.2.5 Glycol water – water or glycol water – glycol water HP

		T upstream (glycol water) (°C)				
		0	10	20	30	40
T downstream (water or glycol water) (°C)						
T flow	T return (*)	(**)	(**)	(**)	35	(**)
1.5	6.5					
7	12					
12.5	17.5					
18	23					
23.5	28.5					

(*): For an upstream temperature of 30-35 °C. For any other upstream source temperature, the test is performed with the nominal downstream source flow rate obtained during the 30-35 °C test.

(**) The nominal flow rate for the upstream source obtained during the 30-35 °C test is retained for the tests at other upstream source temperatures.

A.4.2.6 Ground water – recycled air HP

	T upstream (ground water) (°C)			
	5	10	15	20
T return				
T flow	(*)	15	(*)	(*)
T downstream (recycled air) (°C)				
22				
27				
32				
37				

(*): The nominal flow rate for the upstream source obtained during the 10-15 °C test is retained for the tests at other upstream source temperatures.

A.4.2.7 Water circuit – recycled air HP

	T upstream (circuit water) (°C)				
	0	10	20	30	40
T return					
T flow	(*)	(*)	(*)	35	(*)
T downstream (recycled air) (°C)					
22					
27					
32					
37					

(*): The nominal flow rate for the upstream source obtained during the 30-35 °C test is retained for the tests at other upstream source temperatures.

A.4.2.8 Glycol water – recycled air HP

	T upstream (glycol water) (°C)				
	0	10	20	30	40
T return					
T flow	(*)	(*)	(*)	35	(*)
T downstream (recycled air) (°C)					
22					
27					
32					
37					

(*): The nominal flow rate for the upstream source obtained during the 30-35 °C test is retained for the tests at other upstream source temperatures.

A.4.2.9 Extracted air – water HP

		T upstream (extracted air) (°C)				
		22	27	32	35	37
T downstream (water) (°C)						
T flow	T return (*)					
1.5	6.5					
7	12					
12.5	17.5					
18	23					
23.5	28.5					

(*): For an upstream temperature of 35 °C. For any other source upstream temperature, the test is performed with the nominal flow rate obtained during the 35 °C test.

A.4.2.10 Ground - water HP

		T upstream (ground) (°C)
		30
T downstream (water) (°C)		
T flow	T return	
7	(*)	
18	(*)	

(*): With the water flow rate determined in heating mode

A.4.3 Acoustic power level

Sound power levels shall be determined under the conditions set out in Appendix AA (Part 10) of this certification standard. Outside the building they must comply with the following thresholds:

Heating capacity (in kW)	Sound power (in dB(A))
0 < capacity ≤ 10	≤ 70
10 < capacity ≤ 20	≤ 73
20 < capacity ≤ 50	≤ 78
50 < capacity ≤ 100	No threshold defined

If the measured sound power level of a product exceeds the declared level for the product by more than 2 dB(A), all the range values must be changed on the basis of the deviation observed on the tested product, between the declared sound power value and the test report result.

For multi-split heat pumps, if the measured sound power level of one or more combinations exceeds the declared level by more than 2 dB(A), the certification file will be presented to the Special Committee and the reduction to apply to all the combinations will be studied on a case-by-case basis, depending on the deviations observed and the number of combinations.

A.4.4. Special characteristics of variable power regulation HPs

The manufacturer shall send the means to obtain the minimum continuous operation load ratio from his product under evaluation ($LR_{contmin}$).

A heating capacity test at this load ratio is performed to verify the continuous operation of the HP (no cycling) and record the following performance values:

- The heating capacity so obtained is compared to the nominal heating capacity obtained at the same operating point (pivot point of the matrix if declared) and $LR_{contmin}$ is calculated.
If the difference between the calculated value and the value of $LR_{contmin}$ declared by the manufacturer is less than 10 % of the declared value, the value of $LR_{contmin}$ is then validated.
- if the value of $LR_{contmin}$ is validated, the COP at $LR_{contmin}$ is measured and validated, the $Ccp_{LRcontmin}$ is then calculated and validated.

Note: $LR_{contmin}$ is defined relative to the declared heating capacity at full load at the same operating point.
 $Ccp_{LRcontmin}$ corresponds to the ratio of COP at $LR_{contmin}$ and the COP at full load at the same operating point.

A.4.5. Share of electrical power for the auxiliaries

The share of the electrical power for the auxiliaries in the total electrical power (Ratio) is the ratio between these two powers.

The electrical power for the auxiliaries is measured with the appliance in standby mode according to the provisions of standard Pr NF EN 14825.

A.5. QUALITY CONTROL SPECIFICATIONS

The quality control provisions stated in § 2.3 of the reference apply for these products.

In addition, for these types of heat pumps and for the hydraulic circuit leakage pumps (§2.3.3.2.2), the manufacturer must make a leakage test at at least 0.8 times the maximum rated pressure (Ps) to ensure the absence of leaks.

CERTIFICATION REFERENCE

HEAT PUMP – NF MARK

PART 9 – APPENDIX B

SPECIFIC REQUIREMENTS FOR SWIMMING POOL HPs

CONTENTS

- B.1 Applicability**
- B.2 Reference documents**
- B.3 Definition of systems and ranges**
- B.4 Technical specifications and characterisation methods**
- B.5 Quality control specifications**

B.1. APPLICABILITY

This part of the NF HP reference standard details specific provisions for electrically driven heat pumps used for heating swimming pool water for seasonal and/or annual use, installed outdoors or inside a building.

The certified characteristics are:

- The Coefficient of Performance (COP),
- The heating capacity,
- The absorbed electrical power,
- The acoustic power level.

The products covered are defined according to the following types:

- "outdoor air/swimming pool water" type,
- "(ground)water/swimming pool water" type,
- "glycol-water mix/swimming pool water" type,
- "ground/swimming pool water" type.

B.2. REFERENCE DOCUMENTS:

The documents mentioned in §2.2.2 are completed by the following:

NF EN 14511-1 (December 2011): Air conditioners, liquid chilling packages and heat pumps with electrically driven compressors for space heating and cooling – Part 1: "*Terms and definitions*"

NF EN 14511-2 (December 2011): Air conditioners, liquid chilling packages and heat pumps with electrically driven compressors for space heating and cooling – Part 2: "*Test conditions*"

NF EN 14511-3 (December 2011): Air conditioners, liquid chilling packages and heat pumps with electrically driven compressors for space heating and cooling – Part 3: "*Test methods*"

NF EN 14511-4 (December 2011): Air conditioners, liquid chilling packages and heat pumps with electrically driven compressors for space heating and cooling – Part 4: "*Requirements*"

NF EN 15879-1 (April 2011): Testing and rating of direct exchange ground coupled heat pumps with electrically driven compressors for space heating and/or cooling - Part 1: Direct exchange-to-water heat pumps.

Note: Swimming pool heat pumps are not part of the field of application of standard EN 14511; however this is used to determine the performance of the machine.

B.3. DEFINITION OF SYSTEMS AND RANGES

A heat pump range comprises products with the same components, namely:

- same refrigeration process (for example, number of compressors or stages, etc.)
- same refrigerant
- same compressor type
- same expansion valve type
- same evaporator type
- same condenser type
- same defrost principle (4-way valve or vapour injector)
- same power regulation principle (refrigerant performance management)
- same swimming pool exchanger type

Special cases:

- For technological reasons, it can prove necessary to change compressor technology within a range. One or two products may therefore be added.
- A single product that exists with single-phase and three-phase power supply constitutes two models in the same range. In this case, it must be possible to distinguish between them by their names.
- For heat pumps that can be installed (as they are or with optional equipment) inside or outside, these will be viewed as two product ranges but a single heating capacity measurement will be carried out if the pressure in the duct is less than 25 Pa and two heating capacity measurements will be carried out if the pressure in the duct is greater than 25 Pa (see special test conditions in § A.4.1)
- For a range of appliances offering options incorporated into the heat pump, these constitute different ranges if such options have an impact on the certified features of the heat pump. In this case, the applicant shall complete separate applications for the right to use the NF mark.

B.4. TECHNICAL SPECIFICATIONS AND CHARACTERISATION METHODS

Principles:

- The thermal and acoustic performance declarations are verified by tests,
- COP thresholds are set,
- Acoustic power thresholds are set for certain HP heating capacity levels,
- For certain HP types tests for suitability for this function are performed (hot and cold starts).

Test programme:

The test programme is defined according to the HP type and the seasonal or annual use in the tables below. The selection of the number of products to be tested in a range is defined in § 3.1.3.2.

Conditions for validation of declared values for heating capacities:

If the declared values comply with the measured values taking the applicable tolerances into account, they are validated.

The applicable tolerances on the declared values are defined as follows:

- 5% for low water flow HPs; ($\Delta T = 5 \text{ K}$),
- 10% for high water flow HPs; ($\Delta T = 2 \text{ K}$).

If the declared values do not comply with the measured values, they are reset to the measured values, corrected by the applicable tolerance.

Special test conditions:

For heat pumps with continuous variable capacity control (inverter compressor or other type of power variation), the manufacturer must provide the laboratory with the corresponding setting procedure for obtaining the declared operating points.

During the different heating capacity measurement tests, the supply voltage frequencies and/or speeds are noted for compressors and fans and mentioned in the test report.

For a heat pump range that can be installed (as it is or with optional equipment) indoors or outdoors, whose pressure in the discharge duct (towards the outside) is less than 25 Pa; the heating capacity measurement tests are conducted in the outdoor free air blowing configuration with a pressure equal to 0.

B.4.1 Energy performance in heating mode

The energy performance in heating mode, meaning the heating capacity, the absorbed electrical power and the COP, must be determined under the conditions below. COP thresholds are defined and must be respected.

B.4.1.1 Outdoor air – swimming pool water

✓ *Application for seasonal use*

Low water flow heat pumps ($\Delta T = 5^\circ\text{C}$)				
Evaporator		Swimming pool heating system		Min. COP
Dry bulb temperature ($^\circ\text{C}$)	Wet bulb temperature ($^\circ\text{C}$)	Water inlet temperature ($^\circ\text{C}$)	Water outlet temperature ($^\circ\text{C}$)	
15	12	26	31	4.20
7	6	26	*	3.40

(*) The test is carried out with the water flow determined during the test at $+15 \text{ }^\circ\text{C}$.

High water flow rate heat pumps ($\Delta T = 2^{\circ}\text{C}$)				
Evaporator		Swimming pool heating system		Min. COP
Dry bulb temperature ($^{\circ}\text{C}$)	Wet bulb temperature ($^{\circ}\text{C}$)	Water inlet temperature ($^{\circ}\text{C}$)	Water outlet temperature ($^{\circ}\text{C}$)	
15	12	26	28	4.20
7	6	26	*	3.40

(*) The test is performed with the water flow rate determined during the test at $+15^{\circ}\text{C}$.

A test for suitability for the function must be performed, on one of the appliances selected for determination of thermal performance (see § 3.1.3.2), under the conditions defined below:

- Minimum air temperature $7(6)^{\circ}\text{C}$ with a minimum water temperature of 12°C
- Maximum air temperature $30(20)^{\circ}\text{C}$ with a maximum water temperature of 26°C

For both these conditions, the machine must start and operate for 20 minutes.

✓ **Application for year-round use**

Low water flow heat pumps ($\Delta T = 5^{\circ}\text{C}$)				
Evaporator		Swimming pool heating system		Min. COP
Dry bulb temperature ($^{\circ}\text{C}$)	Wet bulb temperature ($^{\circ}\text{C}$)	Water inlet temperature ($^{\circ}\text{C}$)	Water outlet temperature ($^{\circ}\text{C}$)	
15	12	26	*	4.20
7	6	26	31	3.40
2	1	26	*	2.70

(*) The test is performed with the water flow rate determined during the test at $+7^{\circ}\text{C}$.

High water flow rate heat pumps ($\Delta T = 2^{\circ}\text{C}$)				
Evaporator		Swimming pool heating system		Min. COP
Dry bulb temperature ($^{\circ}\text{C}$)	Wet bulb temperature ($^{\circ}\text{C}$)	Water inlet temperature ($^{\circ}\text{C}$)	Water outlet temperature ($^{\circ}\text{C}$)	
15	12	26	*	4.20
7	6	26	28	3.40
2	1	26	*	2.70

(*) The test is performed with the water flow rate determined during the test at $+7^{\circ}\text{C}$.

A test for suitability for the function must be performed, on one of the appliances selected for determination of thermal performance (see § 3.1.3.2), under the conditions defined below:

- Minimum air temperature $2(1)^{\circ}\text{C}$ with a minimum water temperature of 12°C
- Maximum air temperature $30(20)^{\circ}\text{C}$ with maximum water temperature 26°C

For both these conditions, the machine must start and operate for 20 minutes.

B.4.1.2 (Ground) water – swimming pool water

Low water flow heat pumps ($\Delta T = 5^{\circ}\text{C}$)				
Evaporator		Swimming pool heating system		Min. COP
Water inlet temperature ($^{\circ}\text{C}$)	Water outlet temperature ($^{\circ}\text{C}$)	Water inlet temperature ($^{\circ}\text{C}$)	Water outlet temperature ($^{\circ}\text{C}$)	
10	7	26	31	4.50

High water flow rate heat pumps ($\Delta T = 2^{\circ}\text{C}$)				
Evaporator		Swimming pool heating system		Min. COP
Water inlet temperature ($^{\circ}\text{C}$)	Water outlet temperature ($^{\circ}\text{C}$)	Water inlet temperature ($^{\circ}\text{C}$)	Water outlet temperature ($^{\circ}\text{C}$)	
10	7	26	28	4.50

B.4.1.3. Glycol-water mix-to-swimming pool water

Low water flow heat pumps ($\Delta T = 5^{\circ}\text{C}$)				
Evaporator		Swimming pool heating system		Min. COP
Water inlet temperature ($^{\circ}\text{C}$)	Water outlet temperature ($^{\circ}\text{C}$)	Water inlet temperature ($^{\circ}\text{C}$)	Water outlet temperature ($^{\circ}\text{C}$)	
0	-3	26	31	3.60

High water flow rate heat pumps ($\Delta T = 2^{\circ}\text{C}$)				
Evaporator		Swimming pool heating system		Min. COP
Water inlet temperature ($^{\circ}\text{C}$)	Water outlet temperature ($^{\circ}\text{C}$)	Water inlet temperature ($^{\circ}\text{C}$)	Water outlet temperature ($^{\circ}\text{C}$)	
0	-3	26	28	3.60

B.4.1.4. Ground-to-swimming pool water

Low water flow heat pumps ($\Delta T = 5^{\circ}\text{C}$)			
Evaporator	Swimming pool heating system		Min. COP
Evaporating temperature ($^{\circ}\text{C}$)	Water inlet temperature ($^{\circ}\text{C}$)	Water outlet temperature ($^{\circ}\text{C}$)	
-5	26	31	3.40

High water flow rate heat pumps ($\Delta T = 2^{\circ}\text{C}$)			
Evaporator	Swimming pool heating system		Min. COP
Evaporating temperature ($^{\circ}\text{C}$)	Water inlet temperature ($^{\circ}\text{C}$)	Water outlet temperature ($^{\circ}\text{C}$)	
-5	26	28	3.40

B.4.3 Acoustic power level

Sound power levels shall be determined under the conditions set out in Appendix AA (Part 10) of this certification standard. Outside the building they must comply with the following thresholds:

Heating capacity (in kW)	Sound power (in dB(A))
$0 < \text{capacity} \leq 10$	≤ 70
$10 < \text{capacity} \leq 20$	≤ 73
$20 < \text{capacity} \leq 50$	≤ 78
$50 < \text{capacity} \leq 100$	No threshold defined

If the measured sound power level of a product exceeds the declared level for the product by more than 2 dB(A), all the range values must be changed on the basis of the deviation observed on the tested product, between the declared sound power value and the test report result.

For multi-split heat pumps, if the measured sound power level of one or more combinations exceeds the declared level by more than 2 dB(A), the certification file will be presented to the Special Committee and the reduction to apply to all the combinations will be studied on a case-by-case basis, depending on the deviations observed and the number of combinations.

B.5. QUALITY CONTROL SPECIFICATIONS

The quality control provisions stated in § 2.3 of the reference apply for these products.

In addition, for these types of heat pumps and for:

- hydraulic circuit leak tests (§2.3.3.2.2): The manufacturer shall perform a leak test at at least 1.3 times the maximum permissible pressure (Ps) to ensure that there are no leaks,
- documentation control (§2.3.3.3.3): the general conditions of sale must show the guarantee against corrosion (of 5 years) for the swimming pool exchanger and all parts in contact with the swimming pool water. This provision must be verified and be subject to a record.
- For swimming pool heat pumps for which the NF mark has been obtained with an additional exchanger, the holder shall include in the installation and user manual a copy of the certificate of right of use of the NF mark, identifying the exchanger.
- If appropriate, the installation and user manual must state that the product is intended for seasonal use.

CERTIFICATION REFERENCE

HEAT PUMP – NF MARK

PART 10 – APPENDIX AA

ACOUSTIC TESTS

CONTENTS

- AA.1 REFERENCE DOCUMENTS**
- AA.2 HEAT PUMP INSTALLATION CONFIGURATIONS**
- AA.3 SPECIAL INSTALLATION CONDITIONS**
- AA.4 MEASUREMENT RESOLUTION**

When selecting products from a heat pump range to determine the thermal performances (see Para. 3.1.3.2), just one of these products is used for the sound tests. When a heat pump range may be used either with water or water-glycol mix, the sound tests are carried out with the Glycol-Water Mix appliance. CERTITA will study the influence of the integrated options if necessary when selecting the products, together with the laboratory.

Special cases:

It is possible to test for a range of other appliances. For example for heat pumps with optional components or for multi-split heat pumps, so that each type of indoor unit can be taken into consideration.

AA.1 REFERENCE DOCUMENTS

NF EN 12102 (July 2008): Air conditions, heat pumps and dehumidifiers with electrically driven compressors. Measurement of airborne noise. Determination of the sound power level.

NF EN ISO 3741 (November 2009): Determination of sound power levels of noise sources – Precision methods for broad-band sources in reverberation rooms.

NF EN ISO 9614-1 (November 2009): Acoustics – Determination of sound power levels of noise sources using sound intensity – Part 1: measurements by points

AA.2 HEAT PUMP INSTALLATION CONFIGURATIONS

The system configurations are defined according to:

- the heat sources: water or air
- the HP configuration: single-unit or split
- free air discharge or ducted unit
- the location of the heat pump: indoor or outdoor installation.

An exhaustive analysis is therefore conducted, even though certain configurations may not exist on the current market.

For each of these configurations presented in a diagram, the required sound measurements are specified.

When the heat pump may be sold with a separate hydraulic kit, the kit itself is not subject to the sound tests.

For mono and multi-split systems (indoor air units), the sound power radiated by each type of indoor air unit (sill, wall, ceiling, etc.) is measured at high speed, in ventilation mode only (without operation of the refrigeration part). The low speed measurement may be taken at the applicant's request and will form part of the certified features.

The manufacturer shall provide the laboratory with the procedure enabling the operation of the indoor unit(s) in ventilation mode only, without starting up the refrigeration circuit of the outdoor unit.

Diagram key

- water circuit: in blue
- air connection: in red
- refrigerant connection: in black

AA.2.1 OUTDOOR AIR - WATER HP

AA.2.1.1 Single unit – outdoor installation

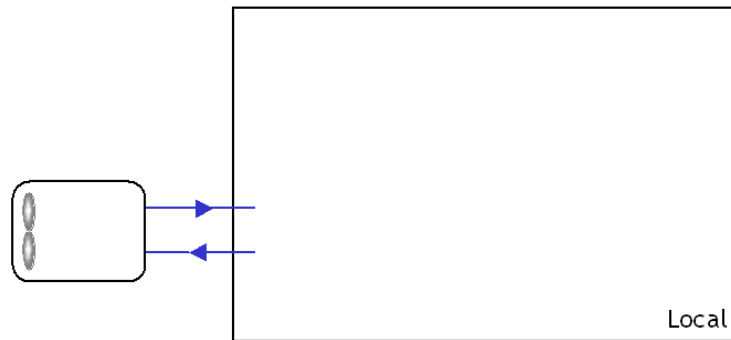

Outside: casing noise.

Inside: no measurement.

Test equipment: reverberant room or intensity method.

AA.2.1.2 Single unit – indoor installation

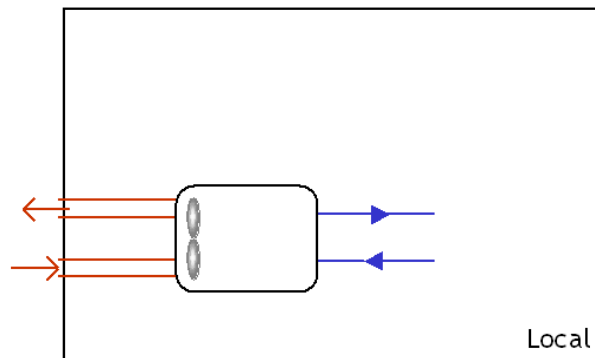

Outside: "global" noise of both air suction and discharge openings.

Inside: noise radiated by the casing.

Test equipment: double reverberant room.

AA.2.1.3 Split system

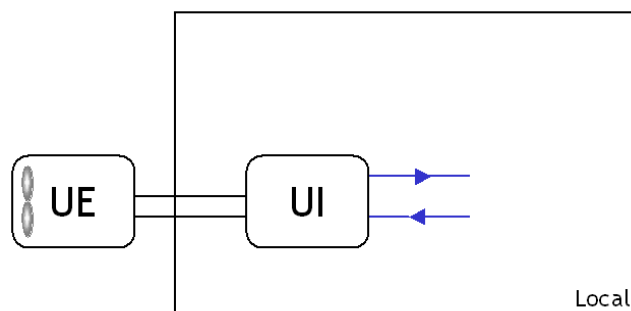

Outside: noise radiated by the casing of the outdoor unit.

Inside: noise radiated by the casing of the indoor unit except for units that only contain one circulator pump.

Test equipment: double reverberant room.

AA.2.2 WATER – RECYCLED AIR HP

AA.2.2.1 Single unit – outdoor installation

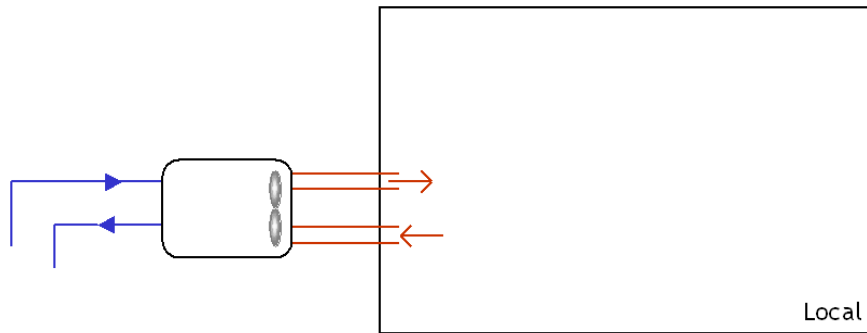

Outside: noise radiated by the casing.
Inside: global airborne noise in the suction and discharge ducts.
Test equipment: double reverberant room.

AA.2.2.2 Single unit – Indoor installation with duct to outside air

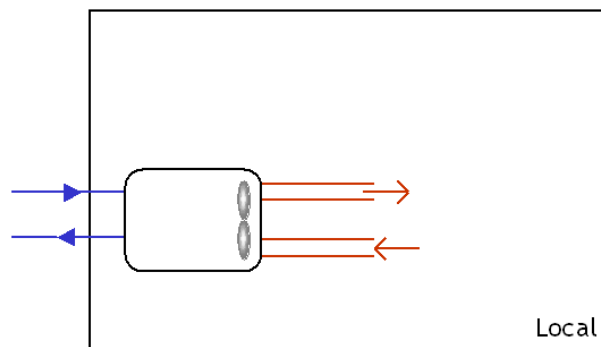

Outside: no measurement.
Inside:
- Airborne noise in the suction duct.
- Airborne noise in the discharge duct.
Test equipment: Double reverberant room.

AA.2.2.3 Single unit – Indoor installation with free discharge

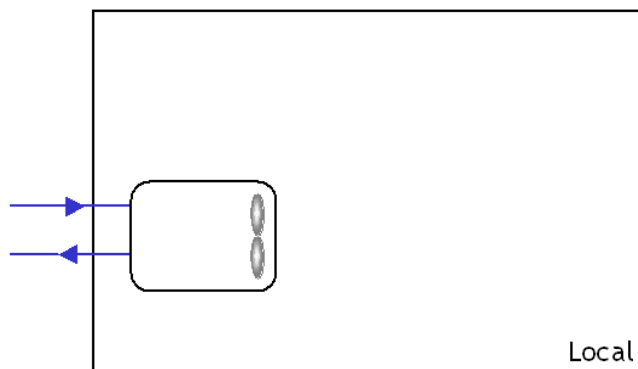

Outside: no measurement.
Inside: noise radiated by the casing.
Test equipment: reverberant room or intensity method.

AA.2.2.4 Split system with ducted indoor unit

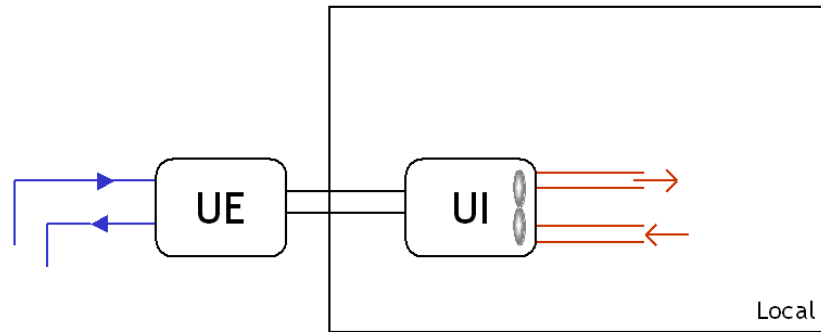

Outside: noise radiated by the casing of the outdoor unit.

Inside (in ventilation mode only):

- For indoor units with suction and discharge ducts:
 - airborne noise in the suction duct,
 - airborne noise in the discharge duct.

- For indoor units with discharge ducts only:
 - noise propagating in the suction duct measured simultaneously with the noise radiated by the casing.
 - airborne noise in the discharge duct.

Test equipment: double reverberant room.

NB: With a double reverberant room, during measurement of the noise radiated by the OU, the IU is fitted with its ducts, but they are not connected to a plenum. The aeraulic operating point of the IU with its ducts must be checked.

AA.2.2.5 Split with unducted indoor unit

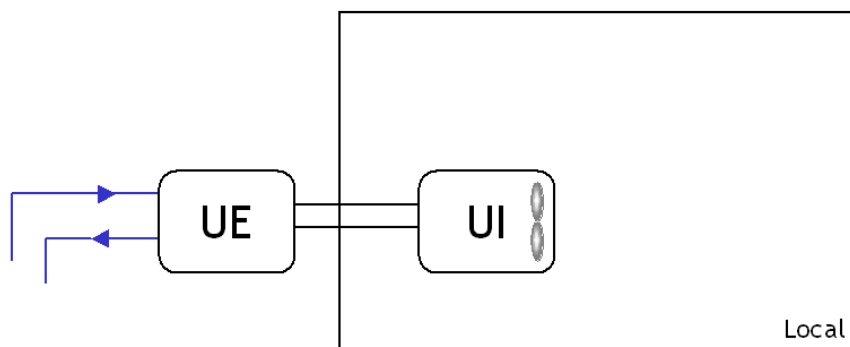

Outside: noise radiated by the casing of the outdoor unit.

Inside (in ventilation mode only): noise radiated by the indoor unit casing.

Test equipment: double reverberant room.

AA.2.3 OUTDOOR AIR – RECYCLED AIR HP

Non ducted single unit – indoor installation

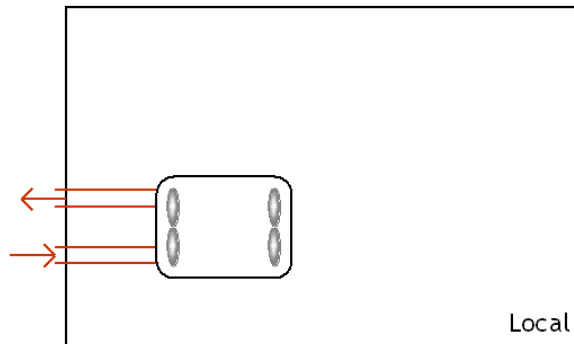

Outside: "global" noise of both air suction and discharge openings.
Inside: noise radiated by the casing.
Test equipment: double reverberant room.

AA.2.3.2 Ducted single unit – indoor installation

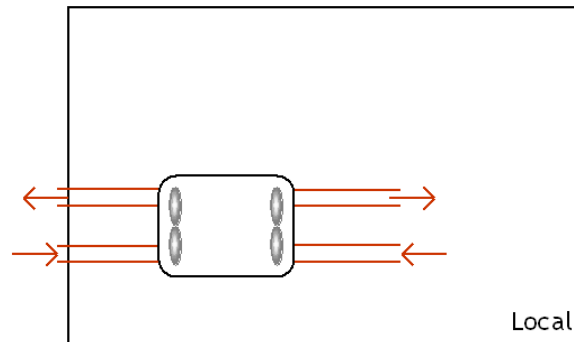

Outdoor side: global noise of both air suction and discharge openings.
Indoor side: - Airborne noise in the suction duct.
- Airborne noise in the discharge duct.
Test equipment: double reverberant room.

AA.2.3.3 Ducted single unit – Outdoor installation

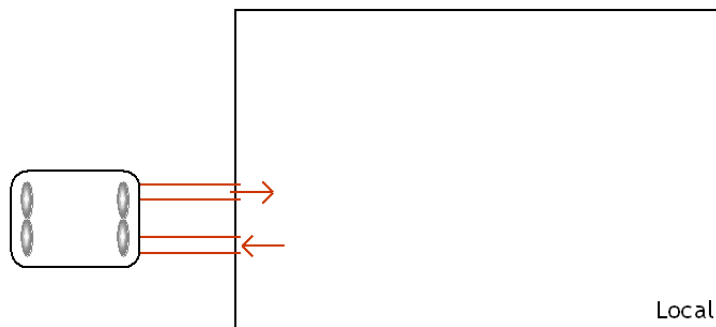

Outside: noise radiated by the casing.
Inside: airborne noise in the suction and discharge ducts.
Test equipment: double reverberant room.

AA.2.3.4 Unducted split

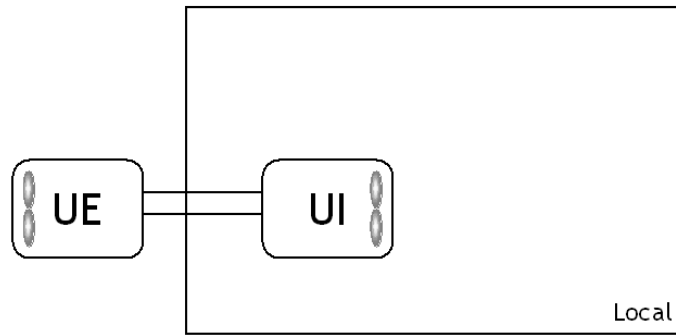

Outside: noise radiated by the casing of the outdoor unit.

Inside (in ventilation mode only): noise radiated by the indoor unit casing.

Test equipment: double reverberant room.

AA.2.3.5 Ducted split

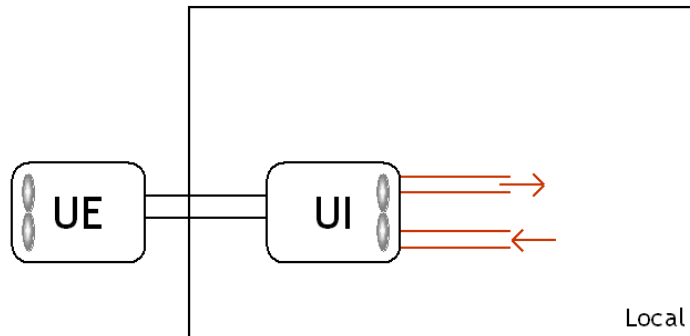

Outside: noise radiated by the casing of the outdoor unit.

Inside (in ventilation mode only):

- For indoor units with suction and discharge ducts:
 - airborne noise in the suction duct,
 - airborne noise in the discharge duct.
- For indoor units with discharge ducts only:
 - suction noise measured at the same time as the noise radiated by the casing.
 - airborne noise in the discharge duct.

Test equipment: double reverberant room.

Remark: With a double reverberant room, during measurement of the noise radiated by the OU, the IU is fitted with its ducts, but they are not connected to a plenum. The aeraulic operating point of the IU with its ducts must be checked.

AA.2.3.6 Multi-split system with unducted indoor units

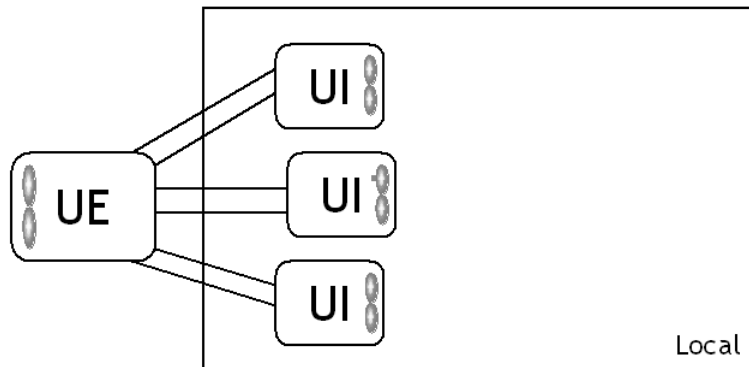

Outside: noise radiated by the casing of the outdoor unit.

Inside (in ventilation mode only): noise radiated by the casing of each type of indoor unit.

Test equipment: double reverberant room.

AA.2.3.7 Multi-split system with ducted indoor units

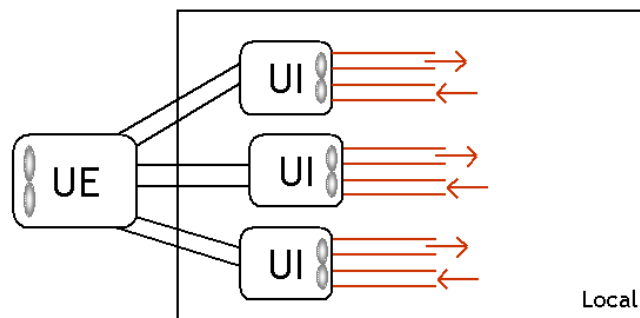

This diagram shows the configuration for the OU test.

The indoor units are the same model and obviously have the same heating capacity.

Outside: noise radiated by the casing of the outdoor unit.

Indoor site (in ventilation mode only):

- For indoor units with suction and discharge ducts:
 - airborne noise in the suction duct,
 - airborne noise in the discharge duct.
- For indoor units with discharge ducts only:
 - suction noise measured at the same time as the noise radiated by the casing.
 - airborne noise in the discharge duct.

Test equipment: double reverberant room.

AA.2.4 EXHAUST AIR – FRESH AIR HP

AA.2.4.1 Ducted single unit – indoor installation

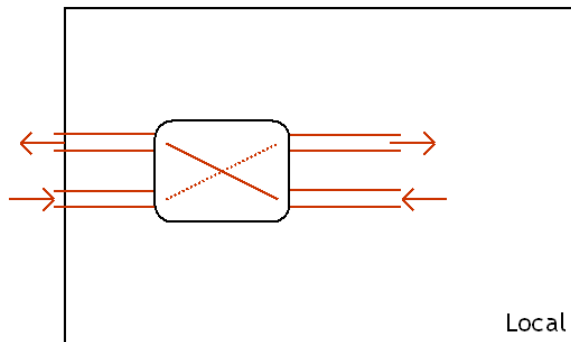

Outside: "global" noise of both air suction and discharge openings.

Indoor side: - airborne noise in the suction duct,
- airborne noise in the discharge duct.

Test equipment: double reverberant room.

NB: With a double reverberant room, when the casing noise is being measured, the ducts are connected to a small plenum and the thermal condition on the exhaust air (20°C) may not be reached.

AA.2.5 EXHAUST AIR - WATER HP

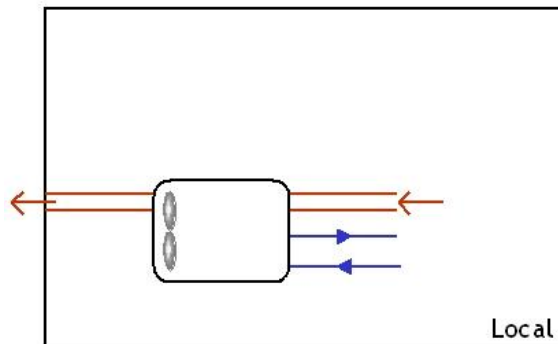

Outside: airborne noise in the discharge duct.

Inside: airborne noise in the suction duct measured at the same time as the noise radiated by the casing.

Test equipment: double reverberant room.

AA.2.6. WATER - WATER or GROUND - WATER or GROUND - GROUND HP

All the heat pumps are packaged type units and can be installed indoors or outdoors.

Outside or inside: casing noise.

Test equipment: reverberant room.

AA.2.7. GROUND - WATER HP

The installation and test configuration details are specified appendix CC.

AA.2.8 OUTDOOR AIR/GROUND CC HP

The installation and test configuration details are specified in appendix DD.

AA.3 SPECIAL INSTALLATION CONDITIONS

AA.3.1. Continuous variable capacity heat pumps

Energy performance (special test conditions)

To determine the sound power levels, the laboratory must adjust the compressor frequency to ± 3 Hz and the fan rotation speed to $\pm 4\%$ of the values measured during the thermal tests. If the frequency and/or speed deviation is not met, the laboratory will request that the manufacturer adjust the machine to obtain these values before undertaking the sound measurements.

Nevertheless, should it not be possible for the tolerance on the fan speed to be met by higher value, and the sound measurement result remains below the value declared by the manufacturer, increased by 2 dB, the heat pump is not refused the NF mark.

AA.3.2 Air ducting

The air coupling ducts must have the following features:

1. length of 1 m

materials: - rectangular duct in 12/10th sheet metal or any other material or similar area density,
or
- circular duct: rolled galvanised duct, or any other material of similar surface density,
In all cases, the ducts must not include absorbing material on the inside,

2. identical cross section to the HP discharge or suction cross section (generally rectangular duct for outdoor air and circular duct for recycled air).

Outdoor side

3. the available pressure is the resulting pressure obtained with these installation characteristics
4. the ducts are not equipped with grids or terminal outlets.

If the unit and test room configuration requires the installation of elbows, priority must be given to a symmetrical configuration for the global noise measurement of the suction inlets and discharge outlets (outdoor side), with an elbow on every duct if necessary. In this case, if the total angle of a duct is greater than 90°, each elbow making it up must not exceed 90°. The total length of each duct may exceed 1m.

Indoor side

5. The static pressure on the indoor side is obtained by adjusting the pressure difference between the two reverberant rooms (value according to the capacity).
6. For heat pumps ducted on the two air circuits, a length of 1 m of rectangular duct shall be used for the ducting on the outdoor side. The length of the duct for the indoor side will depend on the other installation conditions such as the dimensions of the reverberant room.

The assembly of the heat pump with its ducts may be difficult to describe in the test report. In this case, the laboratory must take photos of the installation assembly, attach them to the test report and keep them in the test file.

AA.3.3 "Space heating" heat pumps

The sound tests are carried out under the chosen application conditions for the energy performances.

Regarding a range for which several applications are requested, the sound test is carried out under the conditions corresponding to the last application requested, which presents the highest temperature conditions.

For outdoor air heat pumps, the sound test is performed at an outdoor air temperature of 7(6)°C.

AA.3.4 "Swimming pool" heat pumps:

For "outdoor air-to-water" type swimming pool heat pumps, the sound test is performed at an outdoor air temperature of 15(12)°C and for the water temperature of the swimming pool heating system depending on whether the HP operates with low or high water flow.

For a heat pump range that can be installed (as it is or with optional equipment) indoors or outdoors, two test configurations are required:

External configuration: the heat pump operates without ducts, with an available pressure that is nil at discharge, and its radiated noise is measured (according to diagram § AA.2.1.1):

- Outside: casing noise
- Inside: no measurement

Indoor configuration: the HP is ducted according to § AA.3.2

If the available pressure stated by the manufacturer is ≤ 25 Pa, then the pressure available at 0 is set (see special test conditions in § A.4 or B.4). Otherwise, the available pressure is set at the maximum value P_{max} supplied by the manufacturer. The following is measured (according to diagram § AA.2.1.2):

- Outside: "global" noise of both air suction and discharge openings
- Inside: noise radiated by the casing

AA.4 MEASUREMENT RESOLUTION

The measurement of the sound power level is stated at 1/10th dB.

CERTIFICATION REFERENCE

HEAT PUMP – NF MARK

PART 10 – APPENDIX BB

GROUND – GROUND HP TESTS

CONTENTS

- BB.1 PRODUCT DESCRIPTION**
- BB.2 ENERGY PERFORMANCE**
- BB.3 SOUND PERFORMANCE**

Ground-ground type heat pumps do not fall within the scope of a standard for the determination of heat pump thermal performance.

This exclusion is related to the test method which is very different from those described in the European standard and applicable for heat pumps using air and water as heat transfer fluids.

Pending the preparation and publication of a European standard for these special appliances (CEN TC113 WG10 work), the test protocol below is applied for the certification of ground-ground heat pumps with respect to the heat pump NF mark.

BB.1 PRODUCT DESCRIPTION

Ground-ground heat pumps comprise:

- A module containing the compressor, expansion device, refrigeration accessories and regulation parts
- An evaporator: exchanger made up of a series of polyethylene coated copper tube crowns (in general).
- A condenser: exchanger made up of a series of polyethylene coated copper tube crowns (in general).

BB.2. ENERGY PERFORMANCE

The evaporator crowns are unwound on wooden supports at a height of around 1m 20 in a climatic room. The dry temperature of this climatic room is adjusted and controlled so as to maintain the required evaporation temperature.

The evaporator crowns are unwound on wooden supports at a height of around 1m 20 in a second climatic room. The dry temperature of this climatic room is adjusted and controlled so as to maintain the required condensation temperature.

A flow meter is installed upstream of the condenser to measure the flow of liquid refrigerant. This will make it possible to calculate the condenser's capacity.

Measuring the discharge pressure and liquid pressure associated with the temperatures taken at the same place enables the enthalpies of the liquid refrigerant to be determined. If the machine does not present any liquid pressure tapping, the discharge pressure will be measured to calculate both enthalpies.

The module is installed in an environment at room temperature.

The manufacturer's qualified personnel connect the evaporator and condenser crowns to the module and load with liquid refrigerant.

Instruments include:

- an electrical meter upstream of the machine general power supply
- pressure sensors to measure the suction and discharge pressures and liquid pressure where applicable
- contact probes (PT100) to measure the discharge, liquid and suction temperatures.

The water temperature measurement uncertainty also applies to the measurement of liquid refrigerant temperatures.

The tolerances admitted on the evaporation and condensation temperatures are given in the table below:

	Admissible deviation on the arithmetic mean from the set-point value	Admissible deviation on the individual values from the set-point value
Liquid refrigerant temperature	± 0.2 K	(*)

(*): the test method has a significant influence on the machine operating stability during testing. This value is thus inherent to the machine. Therefore it cannot be quantified.

The heating capacity of the condenser is calculated with the formula:

$$P_{f_{cond}} = qm_{ff} * (h_{ref} - h_{liq})$$

With: qm_{ff} = flow of liquid refrigerant in kg/s
 h_{ref} = enthalpy corresponding to the discharge pressure in kJ/kg
 h_{liq} = enthalpy corresponding to the liquid temperature in kJ/kg

The COP is calculated as follows:

$$COP = P_{f_{Cond}} / P_{elec}$$

With: $P_{f_{Cond}}$ in kW
 P_{elec} in kW

BB.3. SOUND PERFORMANCES

The sound tests are conducted in a reverberant room according to standard NF EN ISO 3741: "Determination of sound power levels of noise sources – Precision methods for broad-band sources in reverberation rooms." in the nominal thermal conditions.

They involve measuring the sound power levels by one-third octave bands between 100 and 10,000 Hz as well as the A weighted global sound power level.

BB.3.1 Operating conditions

The tests only cover the HP module.

The test conditions are those described in appendices A and B of this reference standard.

In the case of tests according to the two applications for the ground-water heat pumps, the test conditions of the "fan-convector" application are selected for the sound test.

BB.3.2 Installation and test methods

The module is placed in a reverberant room. The evaporator crowns are replaced by a water exchanger placed in a second reverberant room.

The condenser is connected to a water circuit with controlled flow rate and temperature. The same suction pressure/temperature as the one obtained at the thermal point is set, as well as the same liquid temperature.

CERTIFICATION REFERENCE

HEAT PUMP – NF MARK

PART 10 – APPENDIX CC

WATER – GROUND HP TESTS

CONTENTS

- CC.1 PRODUCT DESCRIPTION**
- CC.2 ENERGY PERFORMANCE**
- CC.3 SOUND PERFORMANCE**

Water-ground type heat pumps do not fall within the scope of a standard for the determination of heat pump thermal performance.

This exclusion is related to the test method which is very different from those described in the European standard and applicable for heat pumps using air and water as heat transfer fluids.

Pending the preparation and publication of a European standard for these special appliances (CEN TC113 WG10 work), the test protocol below is applied for the certification of ground-ground heat pumps with respect to the heat pump NF mark.

CC.1 PRODUCT DESCRIPTION

The outdoor exchanger (evaporator) is connected to the water, while the condenser is placed directly in the ground of the indoor environment.

A Ground-Water heat pump may be of different types:

- single-unit: the compressor, expansion device and water exchanger are within the same body (a single module), with the condenser crowns separate of course,
- split: the compressor and/or expansion device and/or water exchanger are not within the same body (several modules), and the condenser crowns are of course separate.

CC.2. ENERGY PERFORMANCE

The module(s) is(are) installed in an environment at room temperature and connected to a water loop enabling the required water conditions to be maintained.

The condenser crowns are unwound on wooden supports at a height of around 1m 20 in a climatic room. The dry temperature of this climatic room is adjusted so as to maintain the required condensation temperature.

A flow meter is installed upstream of the condenser to measure the flow of liquid refrigerant. This will make it possible to calculate the condenser's capacity. Loops are made at each end of the flow meter to reduce vibration phenomena of the discharge pipes.

Note: The flow meter will be assembled, as far as possible, in the same environment at room temperature as the module(s).

Otherwise, the liquid refrigerant condensation pressure is measured at the compressor discharge and downstream of the crown outlet collector. Should the machine not present any pressure tapping at these points, the condensation pressure will be measured at the flow meter (placed by the laboratory upstream of the crown inlet collector). This value will also be referred to as the floor outlet pressure measurement (and the loss of load of the condenser crowns will therefore be overlooked).

The liquid refrigerant temperatures are measured upstream of the crown inlet collector (floor inlet) and downstream of the crown collector (floor outlet), with consideration of the heating capacity transmitted in the floor only.

The manufacturer's qualified personnel connect the condenser crowns to the module(s) and load with liquid refrigerant.

The following is measured during the test:

- compressor suction pressures and floor collector inlet and outlet pressures (if available, otherwise see above),
- compressor suction temperatures, floor collector inlet and outlet temperatures,
- liquid refrigerant flow,
- water inlet and outlet temperatures,
- loss of load or pressure available on the water,
- water flow,
- electrical power absorbed,
- liquid refrigerant load and type of liquid.

The tolerances admitted on the condensation temperatures are given in the table below:

	Admissible deviation on the arithmetic mean from the set-point value	Admissible deviation on the individual values from the set-point value
Liquid refrigerant temperature	± 0.3 K	(*)

(*): the test method has a significant influence on the machine operating stability during testing. This value is thus inherent to the machine. Therefore it cannot be quantified.

The heating capacity of the condenser is calculated with the formula:

$$Pf_{cond} = qm_{ff} * (h_{ent} - h_{sort})$$

With: qm_{ff} = flow of liquid refrigerant in kg/s

h_{ent} = enthalpy corresponding to the floor inlet pressure in kJ/kg

h_{sort} = enthalpy corresponding to the floor outlet temperature in kJ/kg

The COP is calculated as follows:

$$COP = \frac{Pf_{cond}}{Pelec}$$

With: Pf_{Cond} in kW
 $Pelec$ in kW

CC.3. SOUND PERFORMANCE

The sound tests are conducted in a reverberant room according to standard NF EN ISO 3741: *"Determination of sound power levels of noise sources – Precision methods for broad-band sources in reverberation rooms."* in the nominal thermal conditions.

They involve measuring the sound power levels by one-third octave bands between 100 and 10,000 Hz as well as the A weighted global sound power level.

CC.3.1 Operating conditions

The tests are only conducted on the heat pump module, comprising at least the compressor.
The test conditions are those described in appendices A and B of this reference standard.

CC.3.2 Installation and test methods

The module is placed in a reverberant room.

The condenser crowns are replaced by a water exchanger placed in a second, adjacent reverberant room and connected to a water loop with set temperature and flow. The same floor inlet and outlet pressures/temperatures are therefore set as those obtained during the thermal test.

The evaporator is connected to a water circuit with controlled temperature and flow to set the test conditions.

CERTIFICATION REFERENCE

HEAT PUMP – NF MARK

PART 10 – APPENDIX DD

OUTDOOR AIR – GROUND HEAT PUMP

CONTENTS

- DD.1 PRODUCT DESCRIPTION**
- DD.2 ENERGY PERFORMANCE**
- DD.3 SOUND PERFORMANCE**

Water-ground type heat pumps do not fall within the scope of a standard for the determination of heat pump thermal performance.

This exclusion is related to the test method which is very different from those described in the European standard and applicable for heat pumps using air and water as heat transfer fluids.

Pending the preparation and publication of a European standard for these special appliances (CEN TC113 WG10 work), the test protocol below is applied for the certification of ground-ground heat pumps with respect to the heat pump NF mark.

DD.1 PRODUCT DESCRIPTION

An Air/Ground heat pump may be of different types:

- single-unit: the compressor, expansion device and water exchanger are within the same body (a single module), with the condenser crowns separate of course,
- split: the compressor and/or expansion device and/or water exchanger are not within the same body (several modules), and the condenser crowns are of course separate.

DD.2. ENERGY PERFORMANCE

The air exchanger module is installed in a climatic room whose dry and wet temperatures are set and controlled so as to maintain the required conditions.

For a split machine, module(s) other than the air exchanger are installed at room temperature.

The condenser crowns are unwound on wooden supports at a height of around 1m 20 in a climatic room. The dry temperature of this climatic room is adjusted so as to maintain the required condensation temperature.

A flow meter is installed upstream of the condenser to measure the flow of liquid refrigerant. This will make it possible to calculate the condenser's capacity. Loops are made at each end of the flow meter to reduce vibration phenomena of the discharge pipes.

Note: The flow meter will be assembled, as far as possible, in an environment at room temperature.

Otherwise, the liquid refrigerant condensation pressure is measured at the compressor discharge and downstream of the crown outlet collector. Should the machine not present any pressure tapping at these points, the condensation pressure will be measured at the flow meter (placed by the CETIAT upstream of the crown inlet collector). This value will also be referred to as the floor outlet pressure measurement (and the loss of load of the condenser crowns will therefore be overlooked).

The liquid refrigerant temperatures are measured upstream of the crown inlet collector (floor inlet) and downstream of the crown collector (floor outlet), with consideration of the heating capacity transmitted in the floor only.

The manufacturer's qualified personnel connect the condenser crowns to the module(s) and load with liquid refrigerant.

The following is measured during the test:

- compressor suction pressures and floor collector inlet and outlet pressures (if available, otherwise see above),
- compressor suction temperatures, floor collector inlet and outlet temperatures,
- liquid refrigerant flow,
- incoming dry and wet temperatures of the evaporator on the air,
- rotation speed of the fan(s),
- electrical power absorbed,
- liquid refrigerant load and type of liquid.

The tolerances admitted on the condensation temperatures are given in the table below:

	Admissible deviation on the arithmetic mean from the set-point value	Admissible deviation on the individual values from the set-point value
Liquid refrigerant temperature	± 0.3 K	(*)

(*): the test method has a significant influence on the machine operating stability during testing. This value is thus inherent to the machine. Therefore it cannot be quantified.

The heating capacity of the condenser is calculated with the formula:

$$Pf_{cond} = qm_{ff} * (h_{ent} - h_{sort})$$

With: qm_{ff} = flow of liquid refrigerant in kg/s

h_{ent} = enthalpy corresponding to the floor inlet pressure in kJ/kg

h_{sort} = enthalpy corresponding to the floor outlet temperature in kJ/kg

The COP is calculated as follows:

$$COP = \frac{Pf_{cond}}{Pelec}$$

With: Pf_{Cond} in kW
 $Pelec$ in kW

DD.3. SOUND PERFORMANCE

The sound tests are conducted in a reverberant room according to standard NF EN ISO 3741: "Determination of sound power levels of noise sources – Precision methods for broad-band sources in reverberation rooms." in the nominal thermal conditions.

They involve measuring the sound power levels by one-third octave bands between 100 and 10,000 Hz as well as the A weighted global sound power level.

DD.3.1 Operating conditions

The tests are only conducted on the heat pump module(s) containing the compressor and air evaporator. The test conditions are those described in appendices A and B of this reference standard.

DD.3.2 Installation and test methods

The module is placed in a reverberant room.

The condenser crowns are replaced by a water exchanger placed in a second, adjacent reverberant room and connected to a water loop with set temperature and flow. The same floor inlet and outlet pressures/temperatures are therefore set as those obtained during the thermal test.

The air evaporator is placed in a reverberant room with set temperature so as to set the desired atmospheric conditions.

If the compressor is integrated in the same module, a single sound power measurement is taken.

If the compressor is placed in another module, this is installed in the adjacent reverberant room with the water loop simulating the condenser crowns.

Both the sound power measurements of the evaporator and compressor are then taken at the same time.